

COLEÇÃO 2025
COLLECTION

Dolce Vita



o teu espelho de água / your own pool

50°

1974
2024

2025

PISCINE
LAGHETTO®

COLEÇÃO 2025 COLLECTION

Dolce Vita



ATENÇÃO



EXTENSÃO DA GARANTIA / Extended warranty

Para obter a extensão de garantia anunciada neste catálogo, o produto deve ser registado pelo cliente final em www.piscinelaghetto.com num prazo de 30 dias a contar da data de entrega da piscina, comprovado por um recibo /fatura fiscal regular.

In order to obtain the extended warranty advertised in this catalogue, the product must be registered by the end customer on www.piscinelaghetto.com within 30 days from the date of sale/delivery of the pool, proven by regular fiscal receipt/invoice.

PISCINE
LAGHETTO®

A Fluidra Commerciale Italia SpA reserva-se o direito de efetuar alterações sem de aviso prévio. Os produtos ilustrados nesta lista de preços são apenas para uso privado.

Qualquer utilização pública ou comercial tem de ser autorizada pela Fluidra Commerciale Italia SpA, que não se responsabiliza pela segurança, filtragem ou pureza da água. O comprador é obrigado a respeitar os regulamentos do país em que a piscina é instalada.

Imagens não contratuais com carácter meramente ilustrativo.

Atenção: As cores apresentadas nesta lista de preços têm como único objetivo ilustrar o produto. Recomendamos-lhe, portanto, que veja diretamente os produtos e/ou as amostras originais de materiais e tecidos Piscine Laghetto.

É PROIBIDA A REPRODUÇÃO, MESMO PARCIAL, DESTA CATÁLOGO / LISTA DE PREÇOS.

Fluidra Commerciale Italia SpA reserves the right to make changes without prior notice. The products illustrated in this price list are for private use only.

Any public or commercial use has to be authorized by Fluidra Commerciale Italia SpA, which does not take responsibility for safety, filtration or purity of water. The purchaser is obliged to observe the regulations of the country in which the pool is installed.

Non-contractual images for illustrative purposes only.

Please note: The colours shown in this price list are for the sole purpose of illustrating the product. They do not refer to a specific colour. We therefore recommend that you view the products and/or the original Piscine Laghetto material and fabric samples directly.

REPRODUCTION, EVEN PARTIAL, OF THIS CATALOGUE / PRICE LIST IS FORBIDDEN

	PAGINA
UMA HISTÓRIA DE FAMÍLIA A family history	4
APRESENTAÇÃO DOLCEVITA ACIMA DO SOLO Introduction of above ground DolceVita	10
DOLCEVITA COM ACABAMENTO EM RATTAN DolceVita Rattan finish	24
DOLCEVITA ACABAMENTO DIVA DolceVita Diva finish	28
DOLCEVITA ACABAMENTO DIVA COM SALA TÉCNICA INTEGRADA (STI) DolceVita Diva LTI finish	32
DOLCEVITA VERSÃO NAKED DolceVita Naked version	36
ACESSÓRIOS Accessories	39
PESOS E MEDIDAS Weights and sizes	50
ANEXOS TÉCNICOS Technical drawings	54
GARANTIA Warranty	60

Todos os conteúdos desta comunicação, incluindo texto, gráficos, layout, fotografias, pertencem, salvo indicação em contrário, à Fluidra Commerciale Italia SpA e não podem de forma alguma ser reproduzidos, publicados, comercializados, distribuídos, transmitidos ou de qualquer forma utilizados por terceiros sem autorização prévia por escrito da Fluidra Commerciale Italia SpA. As marcas registadas, os logótipos e os nomes da Fluidra Commerciale Italia SpA, dos seus parceiros e/ou de terceiros pertencem aos respectivos proprietários e estão protegidos pelas leis actuais de direitos de autor, patentes e propriedade intelectual. Qualquer infração será processada de acordo com a lei.

All the contents of this communication, including text, graphics, layout, photographs, belong, unless otherwise specified, to Fluidra Commerciale Italia SpA and may not in any way be reproduced, published, marketed, distributed, transmitted or in any way used by third parties without prior written authorisation from Fluidra Commerciale Italia SpA. The trademarks, logos and names of Fluidra Commerciale Italia SpA, its partners and/or third parties belong to their respective owners and are protected by current copyright, patent and intellectual property laws. Any violation will be prosecuted according to the law.

UMA HISTÓRIA DE FAMÍLIA

A FAMILY HISTORY

50
1974
2024

Laghetto
PISCINE

A história da Piscine Laghetto começou num verão abafado de Cremona: corria o ano de 1974 e no pátio da Agrisilos, uma empresa produtora de lonas agrícolas, apareceu uma piscina redonda de folha de borracha com um anel insuflável para os filhos dos proprietários, que podiam brincar e refrescar-se no verão quente do Vale do Pó.

“AS GRANDES IDEIAS SURGEM MUITAS VEZES DO ACASO”

A primeira Laghetto tinha acabado de ser criada.

Uma ideia simples que se revelou vencedora desde o início, chamando de imediato a atenção de todos, de tal forma que a patente n.º 168558 foi imediatamente registada.

Foram anos de prosperidade e crescimento económico e a ideia de uma piscina de jardim fácil de construir, bonita e durável conquistou o público a tal ponto que, em pouco tempo, a Piscine Laghetto se tornou a marca de referência para as piscinas residenciais acima do solo.

A história da Piscine Laghetto é uma história de sucesso, de grande intuição, de projectos sempre novos e vanguardistas, caracterizados pela atenção à qualidade e ao serviço, sem nunca perder de vista o estilo e o design italiano.

Com a sua vasta gama de produtos caracterizados por um design único e inconfundível e em quase 50 anos de história, a Piscine Laghetto entrou nas casas e nos jardins de 250.000 famílias em todo o mundo.



1974

“GREAT IDEAS OFTEN ARISE BY CHANCE”

The story of Piscine Laghetto began in a muggy Cremona summer: it was 1974 and in the courtyard of Agrisilos, a company producing tarpaulins for agriculture, a round rubberised sheet swimming pool with an inflatable ring appeared for fun to let the owners' children play and cool off in the heat of the Po Valley summer.

The first Laghetto had just been created.

A simple but winning idea has drawn everyone's attention, to such an extent that patent No. 168558 was immediately filed.

Those were years of prosperity and economic growth and the idea of a garden swimming pool that was easy to build, beautiful and durable won over the public: in a short time Piscine Laghetto became the reference brand for above ground residential swimming pools.

The Piscine Laghetto story is a story of success, of great intuition, always new and avant-garde projects, characterised by attention to quality and service, without ever losing sight of Italian style and design.

During the last 50 years Piscine Laghetto has entered the homes and gardens of 250,000 families all over the world with its vast range of products characterised by a unique and unmistakable design.



CLASSIC

BLUESPRING

Dolce Vita

POP!

PLAYA

ANOS 80'

ANOS 90'

2007

2014

2014

A EMPRESA > THE COMPANY

A PISCINE LAGHETTO® sempre se distinguiu pela sua capacidade de compreender e antecipar as tendências e as expectativas dos seus clientes, procurando propor produtos de excelência técnica e de design icónico.

O serviço pós-venda é outra das prioridades da empresa, para que aqueles que escolhem uma Laghetto possa usufruir da sua piscina de uma forma simples, segura e despreocupada desde o primeiro dia.

Desde 2017, a Agrisilos - Piscine Laghetto passou a fazer parte do **GRUPO FLUIDRA**, um grupo multinacional espanhol cotado na Bolsa de Valores, líder mundial no sector das piscinas e do bem-estar, que em 2019 entrou no IBEX 35, a lista das 35 empresas mais capitalizadas de Espanha.



Piscine Laghetto® has always stood out for its ability to understand and anticipate the trends and expectations of its customers, striving to offer products that are technically excellent and at the same time iconic and design-oriented.

The after-sales service is another of the company's priorities, so that those who choose a Laghetto product can enjoy their pool easily, safely and without worries from day one.

Since 2017, Agrisilos - Piscine Laghetto has become part of the Fluidra Group, a listed Spanish multinational group, world leader in the pool and wellness sector, which in 2019 entered IBEX 35, the list of the 35 most capitalised companies in Spain.

FLUIDRA

PISCINE
LAGHETTO®

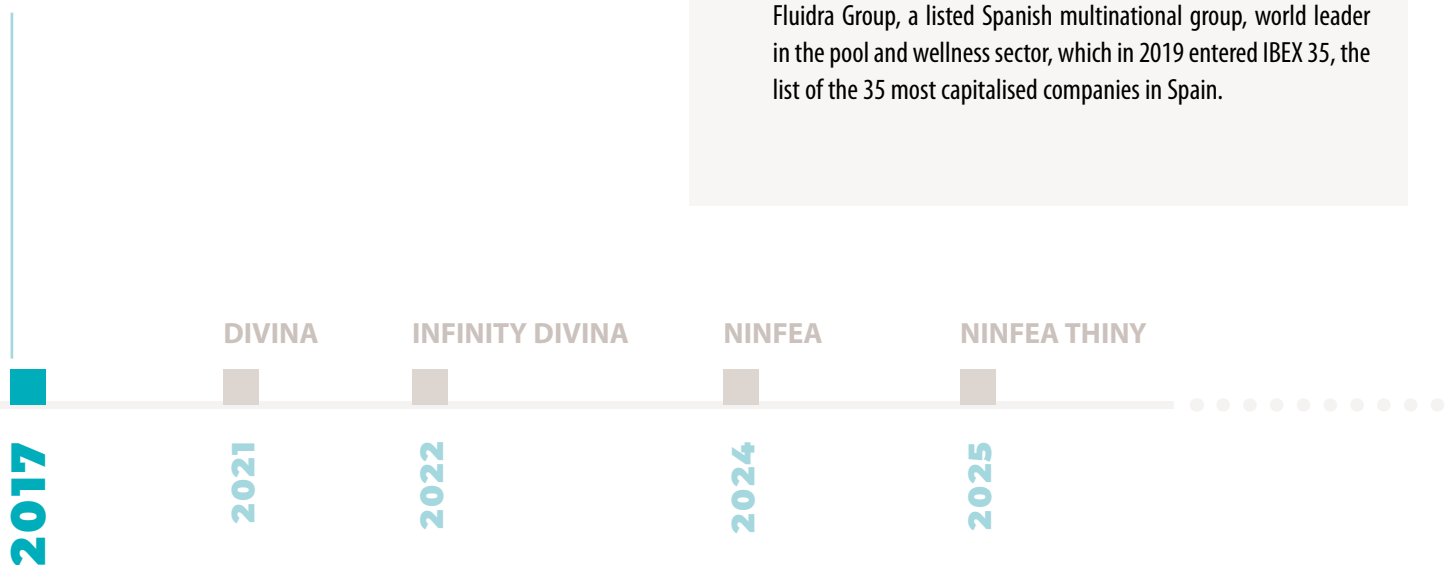



O departamento de produção da Piscine Laghetto sempre esteve localizado na fábrica de Vescovato (CR).

Aqui a empresa ocupa uma área total de cerca de 10.000 metros quadrados, que inclui a área de produção, parte do armazém e escritórios.

Para oferecer aos seus clientes o melhor serviço possível, nos últimos anos a empresa investiu na ampliação da área de armazenamento e expedição, garantindo assim uma maior fiabilidade e pontualidade mesmo em plena época alta.

O NOSSO OBJETIVO É A QUALIDADE!

QUALITY IS OUR FOCUS !

The production department of Piscine Laghetto has always been located in the plant of Vescovato (CR). Here the company covers a total area of around 10,000 square metres, in which the production area, part of the warehouse and the offices are located.

In order to offer the best service to its customers, the company has recently invested in the expansion of the storage and shipping area, which will allow us to be more reliable and punctual during high season.

PISCINE
LAGHETTO[®]

A EMPRESA > THE COMPANY

ITÁLIA E DESIGN > ITALY AND DESIGN

"Estamos conscientes de criar novos mundos e novos conceitos de estilo".

Desde o nascimento da marca, Piscine Laghetto tem sido disruptiva no mundo das piscinas e não só.

O forte ADN italiano feito de arte, cultura, design e génio pode ser encontrado no design de todos os produtos.

Ao longo dos anos, a criatividade da empresa conduziu a um "upgrade" do próprio produto, actualizando-o e renovando-o em termos de design, imagem e mercado de referência.

Para a Piscine Laghetto, a piscina torna-se assim uma peça de mobiliário que se enquadra bem no jardim, debaixo de um alpendre, num terraço ou mesmo no interior da casa.

Um novo conceito de "mobiliário com água" impõe-se impõe-se com a sua originalidade, elegância e singularidade e projecta a essência do produto fora do mundo da piscina.

Não é apenas um objeto de verão a apresentar para completar um ambiente exterior, mas o coração de um projeto inovador de design e mobiliário que se torna transversal a todas as estações e ambientes.



"We are conscious of creating new worlds and new styles".

Since the birth of the brand, Piscine Laghetto has been disruptive in the swimming pool world and beyond.

The strong Italian DNA of art, culture, design and geniality can be found in the design of all products.

Over the years, the company's creativity has led to an upgrade and renewal of the product itself, in terms of design, image and target market.

The swimming pool becomes a piece of furniture that fits pleasantly into the garden, a porch, a terrace or even inside the home.

A new concept of "furnishing with water" imposes itself with its originality, elegance and uniqueness, projecting the essence of the product outside the pool world.

The pool becomes not just a summer object that completes an outdoor environment, but the heart of an innovative design and furnishing project.

This way it becomes transversal to all seasons and environments.





Esta nova forma de conceber o produto é o resultado de anos de presença ativa nas principais feiras do sector do mobiliário, eventos Fuorisalone del Mobile com importantes instalações futuristas e cooperações de prestígio, até à experiência significativa de 2022 a 2023 de um Showroom em Milão Brera, ponto de referência e coração do Design internacional. No outono de 2023, a empresa decidiu equipar a sua sede de Vescovato com um grande showroom aberto aos seus revendedores e concebido como um espaço de inspiração para a difusão do design Piscine Laghetto.

A entrada da empresa no grupo multinacional espanhol Fluidra permitiu-lhe alargar os seus mercados de referência à escala mundial, sem nunca perder o seu carácter **italiano, que sempre foi a essência da Piscine Laghetto.**

A NOSSA ALMA É TODA ITALIANA! OUR SOUL IS ALL ITALIAN !

This new way of conceiving the product is the result after years of active presence at the main furnishing sector fairs, Fuorisalone del Mobile events with important futuristic installations and prestigious co-operations, up to the significant experience from 2022 to 2023 of a Showroom in Milano Brera, a reference point and heart of the international Design. In autumn 2023 the company decided to equip its Vescovato headquarters with a large showroom open to its dealers and conceived as an inspirational space for the diffusion of Piscine Laghetto design.

The company's entry into the Spanish multinational group Fluidra has allowed it to expand its reference markets on a global scale, without ever losing **the distinctive Italian character that is the essence of Piscine Laghetto.**



PISCINE
LAGHETTO[®]

ITÁLIA E DESIGN > ITALY AND DESIGN

Dolce Vita



ELEGÂNCIA E TECNOLOGIA

DOLCEVITA é, no mercado das piscinas acima do solo, o produto que nos últimos anos melhor respondeu aos gostos e às expectativas dos clientes mais exigentes. Graças ao seu design elegante e inovador - e à sólida tecnologia Laghetto, presente no mercado há 50 anos - renovou o mundo das piscinas acima do solo. É um produto ao mesmo tempo, fácil de montar e funcional, com um indiscutível impacto estético, que pode ser inserido em qualquer tipo de contexto, mesmo onde a clássica piscina enterrada não é possível.

A sua versatilidade permite uma instalação rápida e fácil, mesmo em zonas onde apenas é permitida uma utilização sazonal.

A DolceVita dispõe de um sistema de recirculação e filtração que permite a máxima higiene e pureza da água.



ELEGANCE & TECHNOLOGY

Dolcevita is, in the above-ground pool market, the product that in recent years has best met the tastes and expectations of the most demanding customers, renewing the world of above-ground pools. This has been possible thanks to the solid Laghetto technology - on the market for almost 50 years - and its elegant and innovative design.

A product that is at the same time easy to assemble, functional, and of undoubted aesthetic impact. It can be placed in any type of context, even where the classic inground pool can't be installed.

Its versatility allows a quick and easy installation even in areas with only seasonal use permits.

Dolcevita provides a recirculation and filtration system that allows the highest hygiene and purity of water.



O QUE É A DOLCEVITA? > WHAT IS DOLCEVITA?

DOLCEVITA® é uma piscina com uma estrutura modular composta por elementos pré-fabricados e adequadamente montados que suportam a cobertura da piscina: uma membrana estrutural de tração impermeável que é fornecida já soldada e perfurada para acomodar os acessórios internos da piscina.

DOLCEVITA®, independentemente da sua versão, deve ser colocado sobre uma superfície de apoio adequada para suportar o peso da água e da própria estrutura da piscina:

- Na presença de uma base de betão (existente ou nova), os módulos principais podem ser fixados por ancoragens mecânicas ou fixações químicas adequadas, em função das características da base.
- Na ausência de uma base de betão armado, é necessário instalar a base específica de fixação ao solo entre a base da piscina e o solo.

DOLCEVITA® is a swimming pool with a modular structure made of prefabricated and suitably assembled elements that support the pool cover: a waterproof tensile-structural membrane that is supplied already welded and perforated to accommodate the pool's internal accessories.

DOLCEVITA®, regardless of the version, must be placed on a support surface suitable for sustaining the weight of the water and the pool structure itself:

- In the presence of a concrete base (existing or new), the main modules can be fixed using suitable mechanical anchors or chemical fixings, depending on the characteristics of the base.
- In the absence of a reinforced concrete base, it is necessary to install the specific Basement for ground installing between the bottom of the pool and the ground.

UMA ESTRUTURA, QUATRO ESTILOS > ONE STRUCTURE, FOUR STYLES

Está disponível em quatro modelos, cada um com materiais de alta qualidade que garantem a sua durabilidade. DolceVita® is available in four models, each with top-quality materials that guarantee long-lasting use.

DIVA

No nome e na realidade: design linear e moderno, a solução com revestimento e rebordo integrado;

Diva in name and in fact: with its linear and modern design, the solution with panelling and integrated edge;



DIVA LTI

Ainda Diva, mas ainda mais funcional graças a uma sala técnica integrada;

Diva LTI still Diva, but even more functional thanks to an integrated technical room;



ESTILO DOLCEVITA EM VÁRIOS TAMANHOS

DOLCEVITA STYLE IN MANY SIZES

DIVA RATTAN NAKED					
MOD.	CORPO DE ÁGUA water size (m)	SUPERFÍCIE TOTAL overall sizes (m)	ALTURA DA ÁGUA water height (m)	ALTURA TOTAL total height (m)	VOLUME (mc)
24	2 x 4	2,4 x 4,4	1,2	1,3	9,6
25	2 x 5	2,4 x 5,4	1,2	1,3	12
35	3 x 5	3,4 x 5,4	1,2	1,3	18
36	3 x 6	3,4 x 6,4	1,2	1,3	21,6
37	3 x 7	3,4 x 7,4	1,2	1,3	25,2
48	4 x 8	4,4 x 8,4	1,2	1,3	38,4
49	4 x 9	4,4 x 9,4	1,2	1,3	43,2
510	5 x 10	5,4 x 10,4	1,2	1,3	60

DIVA LTI					
MOD.	CORPO DE ÁGUA water size (m)	SUPERFÍCIE TOTAL overall sizes (m)	ALTURA DA ÁGUA water height (m)	ALTURA TOTAL total height (m)	VOLUME (mc)
35	3 x 5	3,4 x 6,1	1,2	1,3	18
36	3 x 6	3,4 x 7,1	1,2	1,3	21,6
37	3 x 7	3,4 x 8,1	1,2	1,3	25,2
48	4 x 8	4,4 x 9,1	1,2	1,3	38,4
49	4 x 9	4,4 x 10,10	1,2	1,3	43,2

RATTAN

Com um design provocador, o Country é o casamento perfeito entre design e tecnologia;

With its provocative country design, it is the perfect combination of design and technology;



NAKED

O mais versátil dos Dolcevita, altamente personalizável de acordo com o gosto do cliente.

O único limite: a imaginação!

The most versatile Dolcevita, highly customisable according to your taste. Imagination will be its only limit.



measure indicative (non vincolanti) the measures are indicatives

OS PORMENORES DO KIT DE PISCINA

POOL KIT DETAILS

ESTRUTURA > STRUCTURE

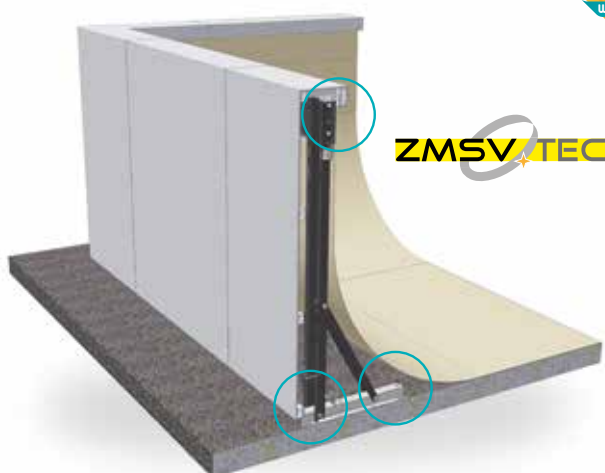

ESTRUTURA

A estrutura da DolceVita foi especificamente estudada e projetada pelos gabinetes técnicos da Laghetto utilizando aço Magnelis® com revestimento a pó com revestimento em pó (tecnologia ZMSV-TEC).

Este tratamento especial confere uma maior resistência aos fenômenos de corrosão.

Em geral, a qualidade dos materiais utilizados garante uma fiabilidade construtiva e uma maior durabilidade. O pé da treliça, bem como as ferragens, são em aço inoxidável.

Em detalhe:

MASTROS DE LATTICE

Aço zinco-magnésio com revestimento em pó.
Pé de cavalete em aço inoxidável AISI304.

VIGAS DE TRELIÇA

Aço zinco-magnésio revestido a pó.

PARAFUSOS

Aço inoxidável A2.



STRUCTURE

The structure of DolceVita, specifically studied and designed by Laghetto's technical offices, is made of Magnelis steel with a powder coating (ZMSV-TEC technology).

This special treatment allows greater resistance against corrosion.

In general, the quality of the materials used guarantees constructive and operational reliability over time.

The trellis foot and all hardware are made of stainless steel.

In detail:

TRELLIS PILLARS

Zinc magnesium steel powder coated structure with stainless steel AISI304 piece of support.

METAL STRUT

Zinc magnesium steel powder coated.

NUTS AND BOLTS

A2 stainless steel.

TECIDO > LINER



TECIDO

As lâminas Dolcevita são feitas de tecido Trevira revestido de 1000 g/m², um produto exclusivo Piscine Laghetto.

A lâmina, uma membrana de alta resistência à tração, é posteriormente tratada com um tratamento anti-UV graças à utilização de aditivos especiais que limitam exponencialmente a deterioração do próprio material.

A lâmina Dolcevita é testada para resistir aos mais extremos testes extremos de tração (430 kg por cada 5 cm).

Cerca de 50 anos de pesquisa e desenvolvimento, com uma estreita colaboração com os fornecedores de tecidos, levaram à formulação de chapas estrutural e quimicamente específicas para o sector das piscinas.

As máquinas de soldar, o coração do departamento de produção, foram especificamente concebidas e fabricadas para responder às exigências tecnológicas e de produção da empresa.

Cada chapa é, portanto, soldada especificamente para obter a máxima resistência às diversas solicitações.

Graças a este facto, os produtos Laghetto são únicos e distinguem-se do resto do mercado.



DOLCEVITA



LINER

Dolcevita pool liners are made from 1000 g/sqm coated Trevira fabric, an exclusive Piscine Laghetto product.

The liner, a highly tensile-resistant membrane, is subsequently treated anti-UV thanks to the use of special additives that exponentially limit the ageing of the material. The Dolcevita liner is tested to withstand the most extreme tensile tests (430 kg every 5 cm).

Piscine Laghetto's vast experience in the production and processing of pool liners it's a synonym of absolute quality and reliability.

Almost 50 years of research, development and close collaboration with carefully selected fabric suppliers have led to the formulation of sheets that are structurally and chemically specific for the swimming pool sector. The welding machines, the most important part of the production department, are specifically designed and manufactured to meet the company's technological production requirements.

Each liner is therefore specifically welded to get the maximum resistance to various stresses, giving Laghetto products the quality and efficiency that distinguish and differentiate them from the rest of the market.

OS PORMENORES DO KIT DE PISCINA

POOL KIT DETAILS

PAINELIZAÇÃO > PANELS

PAINELIZAÇÃO DOLCEVITA

Uma característica distintiva da Dolcevita são os painéis que fazem dela um produto com um design único.

O revestimento é constituído por uma estrutura de alumínio pintado sobre a qual é tecida à mão uma fibra sintética de polipropileno obtida por extrusão.

A elaboração artesanal confere a cada piscina um aspeto único, diferenciando-a no mercado.

Este material de longa duração é particularmente resistente às diferentes condições climáticas e foi testado quanto à sua resistência aos raios UV para uma exposição de mais de 3000 horas.

A resistência às grandes variações de temperatura é também excelente.

A manutenção é fácil, bem como a limpeza, que é efetuada com detergentes neutros e não agressivos.

Os acabamentos Dolcevita adotam dois tipos de revestimento:

RATTAN, com um rebordo em madeira composta, e **DIVA (também na variante DIVA LTI)** com o acabamento exclusivo que integra painel e rebordo numa única peça para um design limpo e moderno.

PANELS

A distinctive feature of Dolcevita, the panels make it a uniquely designed product.

The panelling consists of a painted aluminium structure onto which a synthetic polypropylene fibre obtained by extrusion is woven by hand.

The craftsmanship gives each pool a unique appearance, differentiating it on the market.

This durable material is particularly resistant to various atmospheric agents and has been tested for UV resistance for an exposure of over 3000 hours.

Resistance to wide temperature variations is also excellent. Maintenance is easy as well as cleaning, to be done with neutral non-aggressive detergents.

The Dolcevita finishing adopts two different types of panels:

Rattan, with a composite eco-wood edge, and Diva (also in Diva LTI version) with finishing that integrates panels and edge in a single piece with a linear and modern looking.

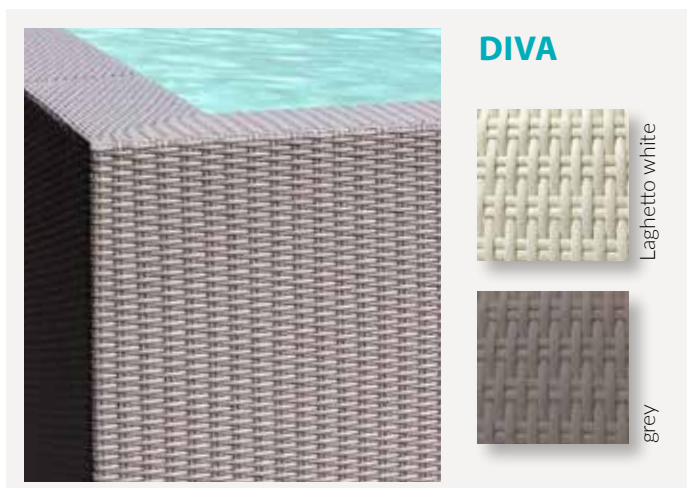

BORDAS DE MADEIRA ECOLÓGICA > ECO WOOD EDGES

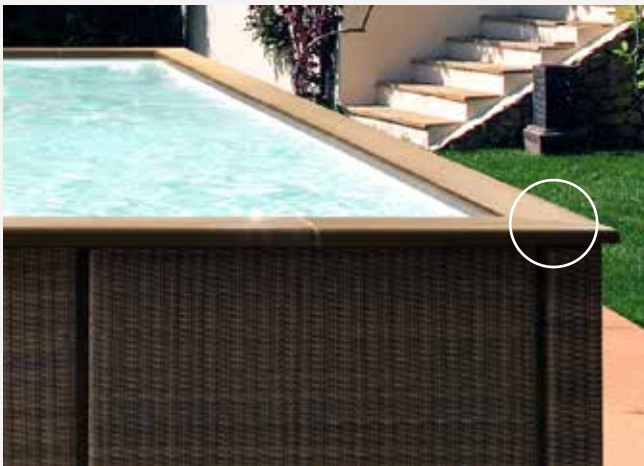

BORDA EM MADEIRA ECOLÓGICA

Nos acabamentos Rattan e Naked, a piscina DolceVita é rodeada por um rebordo em madeira composta.

Está disponível em duas cores para o **RATTAN**, Ardósia e Tabaco, enquanto para o **NAKED** apenas a cor Tabaco está disponível.

A madeira autêntica e elegante é uma escolha estética, tecnológica e sustentável.

Uma madeira de desempenho que perdura no tempo, respeitando a natureza.

ECO WOOD EDGE

In Rattan and Naked versions, the DolceVita pool is surrounded by a composite wood edge.

It is available in two colours: Ardesia and Tobacco.

An authentic and elegant product, chosen as aesthetic and technological sustainable solution.

A high-performance composite long lasting wood, respecting the nature.



Tobacco

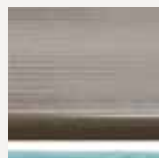

Ardesia

FARÓIS DE LED > LED SPOTS

FARÓIS DE LED BRANCOS

Cada piscina DolceVita é equipada de série com um ou dois faroes LED brancos (consoante o tamanho escolhido) da linha Laghetto colocados na cobertura da piscina, que proporcionam um efeito luminoso impressionante, tanto de dia como de noite.

Estes faroes combinam um alto rendimento luminoso com um baixo consumo (inferior a 8 W) e uma grande durabilidade.

Cada fardo é alimentado a 12V e é fornecido com o seu transformador para ser colocado a uma distância de 3,5 m da piscina.

WHITE LED SPOTS

Each DolceVita pool includes the standard supply of one or two white LED spotlights from the Laghetto line (depending on the size chosen) already positioned on the liner that give to the pools impressive light effects, day and night. These spotlights combine high-performance light output with low power consumption (less than 8 W) and great durability.

Each spotlight is powered at 12V and comes complete with its transformer to be positioned at a distance of 3.5m from the pool.



A LUZ DA DOLCEVITA ILUMINA A NOITE!

DOLCEVITA LIGHT DECORATES THE NIGHT !

OS PORMENORES DO KIT DE PISCINA

POOL KIT DETAILS

ESCADA > LADDER



ESCADA DOLCEVITA

A linha Dolcevita dispõe de dois tipos diferentes de escadas de acesso à piscina.

As versões **RATTAN*** e **NAKED** estão equipadas de série com a escada "Safety" com uma parte exterior rebatível de segurança. Esta pode ser levantada para evitar que as crianças entrem na piscina em alturas em que não é possível vigiá-las.

A escada é composta por tubos de aço inoxidável AISI316 (tubo de Ø 30 mm), degraus de plástico branco polido e uma varanda superior em madeira composta.

*** O kit piscina Dolcevita RATTAN inclui a escada "Safety" enquanto durarem os stocks, depois será substituída pela escada "Luxury".**

As versões **DIVA** e **DIVA LTI** estão equipadas com uma escada específica, a escada "Luxo", inteiramente em aço inox AISI316 (tubo Ø 43 mm), degraus em aço inox com inserções plásticas antiderrapantes e um balcão superior em madeira composta. A escada "Luxury" também pode ser montada nos modelos Rattan e Naked.

Esta versão está equipada com um kit de segurança em plexiglas para impedir a entrada de crianças na piscina.

LADDERS

Rattan* and **Naked** versions are fitted with a standard ladder that includes a safety flip-open part. This has been created to prevent uncorrect children behaviors while they are not supervised.

The ladder is made of polished AISI316 stainless steel tubulars (30 mm tube), white plastic steps and an upper step in composite wood.

*** The Dolcevita Rattan pool kit includes the standard safety ladder model until stocks last, then it will be replaced by the luxury Diva model.**

Diva and **Diva LTI** versions have a dedicated ladder made of AISI316 stainless steel (43 mm tube), stainless steel steps with non-slip plastic insert and an upper step in composite wood. The "Luxury" ladder can also be fitted in Rattan and Naked versions.

A plexiglass safety kit is available on these versions to prevent uncorrect children behaviors.



SAFETY
ladder



LUXURY
ladder



SAFETY
KIT
for
LUXURY
ladder

SKIMMER > SKIMMER



SKIMMER LAGHETTO

O skimmer Piscine Laghetto é fixado à parede da piscina, tem uma cabeça flutuante e funciona por aspiração sobre a água, garantindo assim um elevado grau de limpeza constante ao longo do tempo.

Equipado com um cesto de pré-filtragem, a sua aspiração de 360 graus permite a melhor limpeza possível da piscina com um desempenho superior ao dos skimmers de parede.

A excursão da cabeça flutuante em altura permite uma grande flexibilidade no enchimento da piscina, evitando assim que engula ar e bloqueie a bomba do sistema de filtração.

O skimmer está igualmente equipado com uma série de dispositivos anti-aprisionamento e anti-sucção para a máxima segurança de todos os banhistas.

LAGHETTO SKIMMER

The Piscine Laghetto skimmer is fixed to the pool wall, it has a floating head and works by skimming over the water, thus guaranteeing a high degree of constant cleanliness over time.

Equipped with a pre-filter basket, its 360-degree draught allows the best possible cleaning of the pool with superior performance to wall-mounted skimmers.

The excursion of the floating head in height allows great flexibility in filling the pool, preventing it from drawing air and blocking the filtration system pump. It is also equipped with a series of anti-trapping and anti-sucking devices for maximum safety of all bathers.

KIT DE ASPIRAÇÃO DE LAMA > VACUUM CLEANER

KIT DE ASPIRAÇÃO DE LAMA

A limpeza da sua piscina é fundamental na gestão da piscina.

É por isso que a Piscine Laghetto equipou cada DolceVita com um kit de aspiração a fixar no skimmer para garantir uma limpeza perfeita do fundo.

É composto por uma cabeça de aspiração, pegas modulares em alumínio e mangueiras flutuantes dimensionadas em função do espelho de água da piscina.

VACUUM CLEANER

Cleaning your pool is essential.

That's why Piscine Laghetto has equipped each DolceVita with a vacuum cleaner kit to attach to the skimmer to ensure perfect bottom cleaning.

It consists of a suction head, modular aluminium handles and floating hoses sized according to the pool's water mirror.



OS PORMENORES DO KIT DE PISCINA

POOL KIT DETAILS

FILTRAÇÃO > FILTRATION

FILTRAÇÃO

A Piscine Laghetto, pertencente ao Grupo Fluidra (líder mundial no fornecimento de equipamentos para piscinas), aproveita a experiência da empresa-mãe para **equipar as suas piscinas com sistemas de filtração e depuração de qualidade de construção indiscutível e com os melhores desempenhos do mercado.**

Conscientes da importância da qualidade da água, os sistemas de filtração Dolcevita são adequadamente dimensionados para garantir o mais alto grau de limpeza e higiene.

Estão disponíveis dois tipos de filtração: areia e cartucho.



FILTRATION

As part of the Fluidra Group, one of the world's leading suppliers of swimming pool equipment, Piscine Laghetto takes advantage of the parent company's experience to equip its pools with filtration and purification systems of undisputed construction quality and top market performance.

Aware of the importance of water quality Dolcevita's filtration systems are adequately dimensioned to guarantee maximum cleanliness and hygiene.

Two types of filtration are available: sand and cartridge.



			FILTRO / FILTER	BOMBA / PUMP					
	n° skimmer skimmer	n° envio outlet	tipo type	carga de areia sand load	prefiltro prefilter	caudal max max flow rate	potência power	prevalência max max prevalence	ruído max max noise
	1	1	Filtro de areia cantabric Ø500 mm, caudal 9 m³/h moldado por injeção com válvula superior de 6 vias. Cantabric Ø500 mm injection-moulded sand filter with 6-way top valve	100 Kg	si yes	19 m ³ /h	0,77 kW	13,1 m	78 db
	2	2	Filtro de areia cantabric Ø600 mm, caudal 14 m³/h moldado por injeção com válvula superior de 6 vias Cantabric Ø600 mm injection-moulded sand filter with 6-way top valve	150 Kg	si yes	22 m ³ /h	1,1 kW	16 m	78 db
	1	1	Filtro de cartucho Zodiac, superfície de filtragem 9,3 m², capacidade de filtragem 15-20 microns Zodiac cartridge filter, filter surface area 9.3 m ² , filter capacity 15-20 microns	-	no	11,4 m ³ /h	0,8 kW	11 m	75 db

ACESSÓRIOS

ACCESSORIES

OPCIONAL

KIT BASE > BASEMENT KIT

OPCIONAL

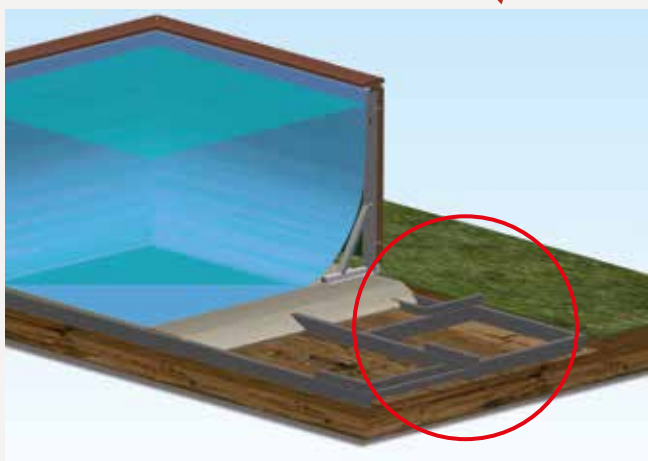

BASE PARA MONTAGEM SEM BETÃO

Graças a este rodapé especial em aço galvanizado e revestido a pó, a piscina pode ser montada diretamente no solo, sem necessidade de uma laje de betão.

O rodapé pode ser acompanhado de um certificado de mobilidade que atesta que a piscina pode ser facilmente removida, mesmo para uma utilização sazonal.

BASEMENT FOR DIRECT ASSEMBLY ON THE GROUND

Thanks to the galvanised steel basement kit painted with powders, it is possible to install the pool directly on the ground, without concrete slab.

It is possible to issue a mobility certificate in which is declared that the pool is easy to be removed, using it just for a seasonal purpose.



KIT FIXAÇÃO NIVELAMENTO > ALIGNMENT FIXING KIT

OPCIONAL

KIT FIXAÇÃO ALINHAMENTO

A função do kit é facilitar a montagem e o alinhamento da estrutura da Dolcevita, evitando os assentamentos normais que ocorrem aquando do enchimento da piscina e que condicionam permanentemente a configuração da piscina.

Com a utilização do Kit de Fixação e Alinhamento, não será mais necessário ajustar as alturas e inclinações da estrutura, como STANDARDmente é feito sem a utilização deste acessório.

A sua utilização é indispensável nas situações em que um dos lados da piscina não é acessível ao operador, por exemplo, quando a piscina é montada junto a uma parede ou, mais geralmente, num espaço limitado.

ALIGNMENT FIXING KIT

The alignment fixing kit function is to facilitate the assembly and alignment of the Dolcevita structure, avoiding the normal settlements that happen during filling operations, giving a permanent asset.

With the use of the Fixing and Alignment Kit it will no longer be necessary to adjust the heights and slopes of the structure, as is normally done without the use of this accessory.

Indispensable in situations where one side of the pool is not accessible to the operator, for example in the case of Dolcevita installed against a wall or, more generally, in a confined environment.



ACESSÓRIOS

ACCESSORIES

OPCIONAL

KIT DE NATAÇÃO EM CONTRACORRENTE **> COUNTERCURRENT SWIMMING KIT**



OPCIONAL

KIT DE NATAÇÃO EM CONTRACORRENTE

Acessório disponível apenas para os modelos DolceVita Diva e Diva STI (para piscinas de 3 ou 4 m de largura). A natação contra-corrente, de fácil instalação, foi criada pela Piscine Laghetto para permitir nadar mesmo em piscinas pequenas.

O Kit Natação Contra Corrente é composto por duas bombas de 1560W cada uma (caudal máximo 36 m³/h, altura manométrica 12,8 m), quatro passagens de aspiração com grelha de proteção, 2 bocais NCC com flanges específicas para montagem nas lonas DolceVita mais os acessórios e tubagens necessários para posicionar a bomba a 3,5 m da piscina, como exigido pelas normas de segurança.

O kit inclui o interruptor pneumático para a ligação e um quadro elétrico específico para o comando e a temporização das bombas.

COUNTERCURRENT SWIMMING KIT

This accessory is available for DolceVita Diva and Diva LTI models only. (just for pools with width of 3/4 meters)

The counter current kit has been specifically created for Piscine Laghetto. It is easy to install and allows swimming even in pool with small dimensions.

The counter current kit is composed by: no. 2 pumps 1560W (max-flow rate 36m³/h, head 12,8m), suction fittings with protective grid, no. 2 NCC nozzles with specific flanges to install it on the DolceVita liners.

As per safety regulation, fittings and piping have to be positioned 3.5m away from pool.

The kit includes the pneumatic button for switching on and a specific switch-board to control and regulate the pumps timing.

KIT DE HIDROMASSAGEM DE 7 JATOS **> 7-JET HYDROMASSAGE KIT**

KIT DE HIDROMASSAGEM DE 7 JATOS

OPCIONAL

Disponível para os modelos DolceVita Rattan, Diva e Diva LTI (para piscinas de 3 ou 4 m de largura).

Especialmente desenvolvida para responder à procura crescente de soluções de bem-estar pessoal, o O kit de hidromassagem é composto por uma bomba de 900 W (caudal máximo 18m³/h, altura manométrica 13,5 m), duas passagens de aspiração com grelha de proteção 7 bocais de hidromassagem com flanges específicas para montagem nas lonas DolceVita, acessórios e tubagens necessárias para colocar a bomba a 3,5 m da piscina, conforme exigido pelas normas de segurança.

O kit inclui o interruptor pneumático para a ligação e um quadro elétrico específico para o comando e a temporização da bomba.

7-JET HYDROMASSAGE KIT

This accessory is available for DolceVita Rattan, Diva and Diva LTI models. (just for pools with width of 3/4 meters)

It has been developed to meet the increasing demand for wellness.

The counter current kit is composed of: no. 2 pumps of 900" (max flow rate 18m³/h, head 13.5m), no. 2 suction fittings with protective grid, no.7 counter current nozzles with specific flanges to install it on DolceVita liners.

As per safety regulation, fitting and piping have to be positioned 3.5m away from the pool.

The kit includes the pneumatic button for switching on and a specific switch-board to control and regulate the pumps timing.



COBERTURAS > POOL COVER

OPCIONAL



COBERTURA DE INVERNO

A cobertura de inverno Light System Plus (verde/preto) com tirantes elásticos permite fechar hermeticamente a piscina durante os meses em que não está a ser utilizada. A utilização da cobertura da piscina, com a utilização dos produtos químicos corretos, permite a correta conservação da água da piscina.

WINTER POOL COVER

The pool winter cover "Light System Plus" (in green/black colors) is equipped with elastic cords rod that allow to close hermetically the pool when not in use. This accessory, jointly with correct chemical products, preserves the water status during winter period.

OPCIONAL



COBERTURA DE VERÃO

A cobertura isotérmica permite reduzir as trocas de calor dia/noite e preservar melhor a temperatura acumulada durante o dia.

Pode também ser deixada a flutuar na água durante o dia, uma vez que o material permite a passagem da luz solar. Esta cobertura é fornecida com rebordo.

SUMMER POOL COVER

The isothermal cover reduces the day/night heat exchange and helps to maintain the water temperature. It can also be left floating on the water during the day, because its fabric allows sunlight to pass through. Isothermal cover for DolceVita is edged for a better finish.

RATTAN

PAG 24

DIVA

PAG 28

DIVA LTI

PAG 32

NAKED

PAG 36

OS KITS DOLCEVITA
THE KITS

RATTAN

KIT PISCINA

POOL KIT

=

1 + 2 + 3 + 4 + 5 +
6 + 7 + 8 + 9 + 10



1 Lona tanque. Pool liner.



2

Estrutura interna.

Internal structure.



3

Sistema de filtração (conforme a tabela).
ATENÇÃO: A INSTALAÇÃO DE FILTRAÇÃO NÃO INCLUI O QUADRO ELÉTRICO.

Filtration System (as in the diagram).

Attention: the filtration system doesn't include the switchboard.



Filtração de areia AstralPool
AstralPool sand filters



Filtração por cartucho Zodiac
Zodiac cartridge filters

4 Faro LED com elevado rendimento luminoso:

n.º 1 facho até ao tamanho 36

n. 2 faros a partir do tamanho 37

(posição standard - ver página 57).

Hight brightness LED spotlight:

n. 1 Spot until model 36 / n. 2 Spots from model 37
(standard placement - see page 57).

5

Painéis exteriores em tecido de fibra sintética.

Exterior panels handwoven fiber.



coffee



grey

10

Borda de piscina em madeira sintética para piscinas DolceVita.

DolceVita Composite Wood Top Edge.

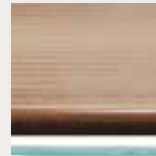

Tobacco



Ardesia

6

Sistema aspiração lamas do fundo.

Vacuum cleaner system.

7

Suportes de painéis em madeira e cantos em ratã.

Wooden panel supports and wicker corner pieces

8

Sistema de escoamento.

Overflow system.

OPCIONAL

Estão disponíveis muitos acessórios para DolceVita RATTAN.

Para mais informações, consulte as páginas dedicadas.

Many accessories available for Rattan DolceVita.
For more information please browse the designated pages.

PAG 40



9







** O kit piscina DolceVita RATTAN inclui uma escada de segurança standard (SAFETY) enquanto durarem os stocks. A escada fornecida será então substituída pela escada LUXURY..

** The DolceVita Rattan pool kit includes the standard ladder (SAFETY) while stocks last. The supplied ladder will then be replaced by the LUXURY ladder.



ESPELHO DE ÁGUA (ÁREA TOTAL) WATER SIZE (TOTAL ENCUMBRANCE)	SISTEMA DE FILTRAÇÃO / FILTERING SYSTEM		CORES / COLOUR	CÓDIGO / CODE
24 2,00 X 4,00 h.1,20 m (2,40 x 4,40)	 10 M³ H DE AREIA 1 SKIMMER 1 SKIMMER 10 m³ h SAND FILTERING SYSTEM	white - coffee		XC24BICFS10BR
		white - grey		XC24BIGRS10BR
		beige - coffee		XC24BECFS10BR
		beige - grey		XC24BEGRS10BR
	 11 M³ H CARTUCHO 1 SKIMMER 1 SKIMMER 11 m³ h CARTRIDGE FILTERING SYSTEM	white - coffee		XC24BICFC11BR
		white - grey		XC24BIGRC11BR
		beige - coffee		XC24BECFC11BR
		beige - grey		XC24BEGRC11BR
25 2,00 X 5,00 h.1,20 m (2,40 x 5,40)	 10 M³ H DE AREIA 1 SKIMMER 1 SKIMMER 10 m³ h SAND FILTERING SYSTEM	white - coffee		XC25BICFS10BR
		white - grey		XC25BIGRS10BR
		beige - coffee		XC25BECFS10BR
		beige - grey		XC25BEGRS10BR
	 11 M³ H CARTUCHO 1 SKIMMER 1 SKIMMER 11 m³ h CARTRIDGE FILTERING SYSTEM	white - coffee		XC25BICFC11BR
		white - grey		XC25BIGRC11BR
		beige - coffee		XC25BECFC11BR
		beige - grey		XC25BEGRC11BR
35 3,00 X 5,00 h.1,20 m (3,40 x 5,40)	 10 M³ H DE AREIA 1 SKIMMER 1 SKIMMER 10 m³ h SAND FILTERING SYSTEM	white - coffee		XC35BICFS10BR
		white - grey		XC35BIGRS10BR
		beige - coffee		XC35BECFS10BR
		beige - grey		XC35BEGRS10BR
	 11 M³ H CARTUCHO 1 SKIMMER 1 SKIMMER 11 m³ h CARTRIDGE FILTERING SYSTEM	white - coffee		XC35BICFC11BR
		white - grey		XC35BIGRC11BR
		beige - coffee		XC35BECFC11BR
		beige - grey		XC35BEGRC11BR

ATENÇÃO: As tonalidades das cores podem variar. ATTENTION: Colour shades may vary.

ESPELHO DE ÁGUA (ÁREA TOTAL) WATER SIZE (TOTAL ENCUMBRANCE)	SISTEMA DE FILTRAÇÃO / FILTERING SYSTEM	CORES / COLOUR	CÓDIGO / CODE
36 3,00 x 6,00 h.1,20 m (3,40 x 6,40)	 10 M³ H DE AREIA 1 SKIMMER 1 SKIMMER 10 m ³ h SAND FILTERING SYSTEM	white - coffee 	XC36BICFS10BR
		white - grey 	XC36BIGRS10BR
		beige - coffee 	XC36BECFS10BR
		beige - grey 	XC36BEGRS10BR
	 11 M³ H CARTUCHO 1 SKIMMER 1 SKIMMER 11 m ³ h CARTRIDGE FILTERING SYSTEM	white - coffee 	XC36BICFC11BR
		white - grey 	XC36BIGRC11BR
		beige - coffee 	XC36BECFC11BR
		beige - grey 	XC36BEGRC11BR
37 3,00 x 7,00 h.1,20 m (3,40 x 7,40)	 10 M³ H DE AREIA 1 SKIMMER 1 SKIMMER 10 m ³ h SAND FILTERING SYSTEM	white - coffee 	XC37BICFS10BR
		white - grey 	XC37BIGRS10BR
		beige - coffee 	XC37BECFS10BR
		beige - grey 	XC37BEGRS10BR
	 11 M³ H CARTUCHO 1 SKIMMER 1 SKIMMER 11 m ³ h CARTRIDGE FILTERING SYSTEM	white - coffee 	XC37BICFC11BR
		white - grey 	XC37BIGRC11BR
		beige - coffee 	XC37BECFC11BR
		beige - grey 	XC37BEGRC11BR
48 4,00 x 8,00 h.1,20 m (4,40 x 8,40)	 10 M³ H DE AREIA 1 SKIMMER 1 SKIMMER 10 m ³ h SAND FILTERING SYSTEM	white - coffee 	XC48BICFS10BR
		white - grey 	XC48BIGRS10BR
		beige - coffee 	XC48BECFS10BR
		beige - grey 	XC48BEGRS10BR
49 4,00 x 9,00 h.1,20 m (4,40 x 9,40)	 15 M³ H DE AREIA 2 SKIMMERS 2 SKIMMERS 15 m ³ h SAND FILTERING SYSTEM	white - coffee 	XC49BICFS15BR
		white - grey 	XC49BIGRS15BR
		beige - coffee 	XC49BECFS15BR
		beige - grey 	XC49BEGRS15BR

ATENÇÃO: As tonalidades das cores podem variar. ATTENTION: Colour shades may vary.

5 years
WARRANTY

ESTRUTURA E LONA
STRUCTURE AND LINER

ACESSÓRIOS
ACCESSORIES

2 years
WARRANTY

DIVA

KIT PISCINA

POOL KIT

=

1 + 2 + 3 + 4 + 5 +
6 + 7 + 8 + 9



1
Lona tanque. Pool liner.



white



beige

5
Painéis com rebordo integrado.
Panels with integrated top edge.



Laghetto white

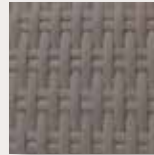

grey



2
Estrutura interna.
Internal structure.



6
Sistema de aspiração de lamas do fundo.
Vacuum cleaner system.

3
Sistema de filtração (conforme a tabela).
ATENÇÃO: A INSTALAÇÃO DE FILTRAÇÃO NÃO INCLUI O QUADRO ELÉTRICO.

Filtration System (as in the diagram).
Attention: the filtration system doesn't include the switchboard.



Filtração de areia AstralPool
AstralPool sand filters



Filtração por cartucho Zodiac
Zodiac cartridge filters

7
Suportes de painéis em aço.
Steel panels-supports.

8
Sistema de escoamento.
Overflow system.

4 **Faro LED com elevado rendimento luminoso:**

n.º 1 faro até ao tamanho 36
n.º 2 faroes a partir do tamanho 37
(posição standard - ver página 57).

Hight brightness LED spotlight:
n. 1 Spot until model 36 / n. 2 Spots from model 37
(standard placement - see page 57).

9
Escada de luxo para DolceVita Diva.
Luxury ladder specific for Diva version.

































OPCIONAL































Existem muitos acessórios disponíveis para DolceVita Diva. Para mais informações, consulte as páginas dedicadas.

Many accessories available for Diva DolceVita. For more information please browse the designated pages.





PAG 40

ESPELHO DE ÁGUA (ÁREA TOTAL) WATER SIZE (TOTAL ENCUMBRANCE)	SISTEMA DE FILTRAÇÃO / FILTERING SYSTEM		CORES / COLOUR	CÓDIGO / CODE
<p>24</p> <p>2,00 X 4,00</p> <p>h.1,20 m (2,40 x 4,40)</p>	 <p>10 M³ H DE AREIA 1 SKIMMER 1 SKIMMER 10 m³ h SAND FILTERING SYSTEM</p>	white - grey		XC24BIGRS10D
		white - L. white		XC24BIBIS10D
		beige - grey		XC24BEGRS10D
		beige - L. white		XC24BEBIS10D
	 <p>11 M³ H CARTUCHO 1 SKIMMER 1 SKIMMER 11 m³ h CARTRIDGE FILTERING SYSTEM</p>	white - grey		XC24BIGRC11D
		white - L. white		XC24BIBIC11D
		beige - grey		XC24BEGRC11D
		beige - L. white		XC24BEBIC11D
<p>25</p> <p>2,00 X 5,00</p> <p>h.1,20 m (2,40 x 5,40)</p>	 <p>10 M³ H DE AREIA 1 SKIMMER 1 SKIMMER 10 m³ h SAND FILTERING SYSTEM</p>	white - grey		XC25BIGRS10D
		white - L. white		XC25BIBIS10D
		beige - grey		XC25BEGRS10D
		beige - L. white		XC25BEBIS10D
	 <p>11 M³ H CARTUCHO 1 SKIMMER 1 SKIMMER 11 m³ h CARTRIDGE FILTERING SYSTEM</p>	white - grey		XC25BIGRC11D
		white - L. white		XC25BIBIC11D
		beige - grey		XC25BEGRC11D
		beige - L. white		XC25BEBIC11D
<p>35</p> <p>3,00 X 5,00</p> <p>h.1,20 m (3,40 x 5,40)</p>	 <p>10 M³ H DE AREIA 1 SKIMMER 1 SKIMMER 10 m³ h SAND FILTERING SYSTEM</p>	white - grey		XC35BIGRS10D
		white - L. white		XC35BIBIS10D
		beige - grey		XC35BEGRS10D
		beige - L. white		XC35BEBIS10D
	 <p>11 M³ H CARTUCHO 1 SKIMMER 1 SKIMMER 11 m³ h CARTRIDGE FILTERING SYSTEM</p>	white - grey		XC35BIGRC11D
		white - L. white		XC35BIBIC11D
		beige - grey		XC35BEGRC11D
		beige - L. white		XC35BEBIC11D

ATENÇÃO: As tonalidades das cores podem variar. ATTENTION: Colour shades may vary.

ESPELHO DE ÁGUA (ÁREA TOTAL) WATER SIZE (TOTAL ENCUMBRANCE)	SISTEMA DE FILTRAÇÃO / FILTERING SYSTEM		CORES / COLOUR	CÓDIGO / CODE
<p>36</p> <p>3,00 x 6,00</p> <p>h.1,20 m (3,40 x 6,40)</p>		<p>10 M³ H DE AREIA 1 SKIMMER 1 SKIMMER 10 m³ h SAND FILTERING SYSTEM</p>	white - grey 	XC36BIGRS10D
		white - L. white 	XC36BIBIS10D	
	beige - grey 	XC36BEGRS10D		
	beige - L. white 	XC36BEBIS10D		
		<p>11 M³ H CARTUCHO 1 SKIMMER 1 SKIMMER 11 m³ h CARTRIDGE FILTERING SYSTEM</p>	white - grey 	XC36BIGRC11D
		white - L. white 	XC36BIBIC11D	
beige - grey 		XC36BEGRC11D		
beige - L. white 		XC36BEBIC11D		
<p>37</p> <p>3,00 x 7,00</p> <p>h.1,20 m (3,40 x 7,40)</p>		<p>10 M³ H DE AREIA 1 SKIMMER 1 SKIMMER 10 m³ h SAND FILTERING SYSTEM</p>	white - grey 	XC37BIGRS10D
		white - L. white 	XC37BIBIS10D	
	beige - grey 	XC37BEGRS10D		
	beige - L. white 	XC37BEBIS10D		
		<p>11 M³ H CARTUCHO 1 SKIMMER 1 SKIMMER 11 m³ h CARTRIDGE FILTERING SYSTEM</p>	white - grey 	XC37BIGRC11D
		white - L. white 	XC37BIBIC11D	
beige - grey 		XC37BEGRC11D		
beige - L. white 		XC37BEBIC11D		
<p>48</p> <p>4,00 x 8,00 h.1,20 m (4,40 x 8,40)</p>		<p>10 M³ H DE AREIA 1 SKIMMER 1 SKIMMER 10 m³ h SAND FILTERING SYSTEM</p>	white - grey 	XC48BIGRS10D
		white - L. white 	XC48BIBIS10D	
		beige - grey 	XC48BEGRS10D	
		beige - L. white 	XC48BEBIS10D	
<p>49</p> <p>4,00 x 9,00 h.1,20 m (4,40 x 9,40)</p>		<p>15 M³ H DE AREIA 2 SKIMMERS 2 SKIMMERS 15 m³ h SAND FILTERING SYSTEM</p>	white - grey 	XC49BIGRS15D
		white - L. white 	XC49BIBIS15D	
		beige - grey 	XC49BEGRS15D	
		beige - L. white 	XC49BEBIS15D	

ATENÇÃO: As tonalidades das cores podem variar. ATTENTION: Colour shades may vary.

ESPELHO DE ÁGUA (ÁREA TOTAL)WATER SIZE (TOTAL ENCUMBRANCE)	SISTEMA DE FILTRAÇÃO / FILTERING SYSTEM		CORES / COLOUR	CÓDIGO / CODE
<p>510</p> <p>5,00 x 10,00 h.1,20 m (5,40 x 10,40)</p>		<p>15 M³ H DE AREIA 2 SKIMMERS 2 SKIMMERS 15 m³ h SAND FILTERING SYSTEM</p>	<p>white - grey </p> <p>white - L. white </p> <p>beige - grey </p> <p>beige - L. white </p>	<p>XC510BIGRS15D</p> <p>XC510BIBIS15D</p> <p>XC510BEGRS15D</p> <p>XC510BEBIS15D</p>

ATENÇÃO: As tonalidades das cores podem variar. **ATTENTION:** Colour shades may vary.

NOTAS

5 years
WARRANTY

ESTRUTURA E LONA
STRUCTURE AND LINER

ACESSÓRIOS
ACCESSORIES

2 years
WARRANTY

DIVA LTI

KIT PISCINA

POOL KIT

=

1 + 2 + 3 + 4 + 5 +
6 + 7 + 8 + 9 + 10



1
Lona tanque. Pool liner.



white



beige

5
Painéis com rebordo integrado.
Panels with integrated top edge.



Laghetto white

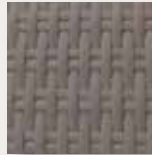

grey

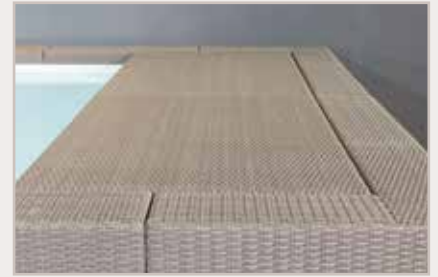

2
Estrutura interna.
Internal structure.



6
Sistema de aspiração de lamas do fundo.
Vacuum cleaner system.

3
Sistema de filtração (conforme a tabela).
ATENÇÃO: A INSTALAÇÃO DE FILTRAÇÃO NÃO INCLUI O QUADRO ELÉTRICO.

Filtration System (as in the diagram).
Attention: the filtration system doesn't include the switchboard.



Filtração de areia AstralPool
AstralPool sand filters



Filtragem por cartucho Zodiac
Zodiac cartridge filters

7
Suportes de painéis em aço.
Steel panels-supports.

8
Transbordamento do sistema.
Overflow system.

9
Escada de luxo para DolceVita Diva.
Luxury ladder specific for Diva version.



10
Sala técnica integrada com escotilha de acesso.
NOTA:
O TETO DA SALA TÉCNICA NÃO É RESISTENTE E NÃO É PESADO.

INTEGRATED TECHNICAL ROOM WITH ACCESS DOOR.
CAUTION:
THE TECHNICAL ROOM IS NOT LOAD-BEARING.
NO PERSONS ALLOWED ON IT.

































OPCIONAL

Existem muitos acessórios disponíveis para a DolceVita Diva LTI. Para mais informações, consulte as páginas dedicadas.

Many accessories available for Diva LTI DolceVita. For more information please browse the designated pages.

PAG 40

ESPELHO DE ÁGUA (ÁREA TOTAL) WATER SIZE (TOTAL ENCUMBRANCE)	SISTEMA DE FILTRAÇÃO / FILTERING SYSTEM		CORES / COLOUR	CÓDIGO / CODE
<p>35</p> <p>3,00 X 5,00</p> <p>h.1,20 m (3,40 x 6,10)</p>	 <p>10 M³ H DE AREIA 1 SKIMMER 1 SKIMMER 10 m³ h SAND FILTERING SYSTEM</p>	white - grey		XC35BIGRS10DG
		white - L. white		XC35BIBIS10DG
		beige - grey		XC35BEGRS10DG
		beige - L. white		XC35BEBIS10DG
	 <p>11 M³ H CARTUCHO 1 SKIMMER 1 SKIMMER 11 m³ h CARTRIDGE FILTERING SYSTEM</p>	white - grey		XC35BIGRC11DG
		white - L. white		XC35BIBIC11DG
		beige - grey		XC35BEGRC11DG
		beige - L. white		XC35BEBIC11DG
<p>36</p> <p>3,00 X 6,00</p> <p>h.1,20 m (3,40 x 7,10)</p>	 <p>10 M³ H DE AREIA 1 SKIMMER 1 SKIMMER 10 m³ h SAND FILTERING SYSTEM</p>	white - grey		XC36BIGRS10DG
		white - L. white		XC36BIBIS10DG
		beige - grey		XC36BEGRS10DG
		beige - L. white		XC36BEBIS10DG
	 <p>11 M³ H CARTUCHO 1 SKIMMER 1 SKIMMER 11 m³ h CARTRIDGE FILTERING SYSTEM</p>	white - grey		XC36BIGRC11DG
		white - L. white		XC36BIBIC11DG
		beige - grey		XC36BEGRC11DG
		beige - L. white		XC36BEBIC11DG
<p>37</p> <p>3,00 X 7,00</p> <p>h.1,20 m (3,40 x 8,10)</p>	 <p>10 M³ H DE AREIA 1 SKIMMER 1 SKIMMER 10 m³ h SAND FILTERING SYSTEM</p>	white - grey		XC37BIGRS10DG
		white - L. white		XC37BIBIS10DG
		beige - grey		XC37BEGRS10DG
		beige - L. white		XC37BEBIS10DG
	 <p>11 M³ H CARTUCHO 1 SKIMMER 1 SKIMMER 11 m³ h CARTRIDGE FILTERING SYSTEM</p>	white - grey		XC37BIGRC11DG
		white - L. white		XC37BIBIC11DG
		beige - grey		XC37BEGRC11DG
		beige - L. white		XC37BEBIC11DG

ATENÇÃO: As tonalidades das cores podem variar. ATTENTION: Colour shades may vary.

photogallery



5 years
WARRANTY

ESTRUTURA E LONA
STRUCTURE AND LINER

ACESSÓRIOS
ACCESSORIES

2 years
WARRANTY

NAKED

KIT PISCINA

POOL KIT

=

1 + 2 + 3 + 4 + 5 +
6 + 7 + 8 + 9



1

Lona tanque. Pool liner.



white

beige

2

Estrutura interna.



Internal structure.

3

Sistema de filtração (conforme a tabela).
**ATENÇÃO: A INSTALAÇÃO DE FILTRAÇÃO
NÃO INCLUI O QUADRO ELÉTRICO.**

Filtration System (as in the diagram).

Attention: the filtration system doesn't include the switchboard.



Filtragem de areia AstralPool
AstralPool sand filters



Filtragem por cartucho Zodiac
Zodiac cartridge filters

4 Faro LED com elevado rendimento luminoso:

n.º 1 faro até ao tamanho 26

n. 2 faroes a partir do tamanho 37
(posição standard - ver página 57).

Hight brightness LED spotlight:

n. 1 Spot until model 36 / n. 2 Spots from model 37
(standard placement - see page 57).



5

Suportes de painéis de madeira.

Wooden panel-supports.

6

Sistema de aspiração de lamas do fundo.

Vacuum cleaner system.

7

Sistema de transbordamento.

Overflow system.

9

Borda de piscina em madeira sintética
para piscinas DolceVita.

DolceVita Composite Wood Top Edge.



Tobacco



Ardesia

OPCIONAL

Existem muitos acessórios disponíveis
para a DolceVita Naked.
Para mais informações, consulte as
páginas dedicadas.

Many accessories available for Naked DolceVita.
For more information please browse the
designated pages.

PAG 40

NAKED

ESTA VERSÃO DA DOLCEVITA NÃO INCLUI
OS PANÉIS.

THIS DOLCEVITA VERSION DOES NOT
INCLUDE PANELS



9

** O kit piscina DolceVita NAKED inclui uma escada
de segurança standard (SAFETY) enquanto durarem os stocks.
A escada fornecida será então substituída pela escada LUXURY.

** The DolceVita NAKED pool kit includes the standard ladder (SAFETY)
while stocks last. The supplied ladder will then be replaced by the LUXURY
ladder.



ESPELHO DE ÁGUA (ÁREA TOTAL) WATER SIZE (TOTAL ENCUMBRANCE)	SISTEMA DE FILTRAÇÃO / FILTERING SYSTEM		CORES / COLOUR	CÓDIGO / CODE
24 2,00 X 4,00 h.1,20 m (2,40 x 4,40)	 10 M³ H DE AREIA 1 SKIMMER 1 SKIMMER 10 m³ h SAND FILTERING SYSTEM	white - tobacco		XC24BIS10BN
		white - ardesia		XC24BIS10BGN
		beige - tobacco		XC24BES10BN
		beige - ardesia		XC24BES10BGN
	 11 M³ H CARTUCHO 1 SKIMMER 1 SKIMMER 11 m³ h CARTRIDGE FILTERING SYSTEM	white - tobacco		XC24BIC11BN
		white - ardesia		XC24BIC11BGN
		beige - tobacco		XC24BEC11BN
		beige - ardesia		XC24BEC11BGN
25 2,00 X 5,00 h.1,20 m (2,40 x 5,40)	 10 M³ H DE AREIA 1 SKIMMER 1 SKIMMER 10 m³ h SAND FILTERING SYSTEM	white - tobacco		XC25BIS10BN
		white - ardesia		XC25BIS10BGN
		beige - tobacco		XC25BES10BN
		beige - ardesia		XC25BES10BGN
	 11 M³ H CARTUCHO 1 SKIMMER 1 SKIMMER 11 m³ h CARTRIDGE FILTERING SYSTEM	white - tobacco		XC25BIC11BN
		white - ardesia		XC25BIC11BGN
		beige - tobacco		XC25BEC11BN
		beige - ardesia		XC25BEC11BGN
35 3,00 X 5,00 h.1,20 m (3,40 x 5,40)	 10 M³ H DE AREIA 1 SKIMMER 1 SKIMMER 10 m³ h SAND FILTERING SYSTEM	white - tobacco		XC35BIS10BN
		white - ardesia		XC35BIS10BGN
		beige - tobacco		XC35BES10BN
		beige - ardesia		XC35BES10BGN
	 11 M³ H CARTUCHO 1 SKIMMER 1 SKIMMER 11 m³ h CARTRIDGE FILTERING SYSTEM	white - tobacco		XC35BIC11BN
		white - ardesia		XC35BIC11BGN
		beige - tobacco		XC35BEC11BN
		beige - ardesia		XC35BEC11BGN

ATENÇÃO: As tonalidades das cores podem variar. ATTENTION: Colour shades may vary.

ESPELHO DE ÁGUA (ÁREA TOTAL) WATER SIZE (TOTAL ENCUMBRANCE)	SISTEMA DE FILTRAÇÃO / FILTERING SYSTEM		CORES / COLOUR	CÓDIGO / CODE
<h2>36</h2> <p>3,00 x 6,00</p> <p>h.1,20 m (3,40 x 6,40)</p>	 <p>10 M³ H DE AREIA 1 SKIMMER 1 SKIMMER 10 m³ h SAND FILTERING SYSTEM</p>	white - tobacco		XC36BIS10BN
		white - ardesia		XC36BIS10BGN
		beige - tobacco		XC36BES10BN
		beige - ardesia		XC36BES10BGN
	 <p>11 M³ H CARTUCHO 1 SKIMMER 1 SKIMMER 11 m³ h CARTRIDGE FILTERING SYSTEM</p>	white - tobacco		XC36BIC11BN
		white - ardesia		XC36BIC11BGN
		beige - tobacco		XC36BEC11BN
		beige - ardesia		XC36BEC11BGN
<h2>37</h2> <p>3,00 x 7,00</p> <p>h.1,20 m (3,40 x 7,40)</p>	 <p>10 M³ H DE AREIA 1 SKIMMER 1 SKIMMER 10 m³ h SAND FILTERING SYSTEM</p>	white - tobacco		XC37BIS10BN
		white - ardesia		XC37BIS10BGN
		beige - tobacco		XC37BES10BN
		beige - ardesia		XC37BES10BGN
	 <p>11 M³ H CARTUCHO 1 SKIMMER 1 SKIMMER 11 m³ h CARTRIDGE FILTERING SYSTEM</p>	white - tobacco		XC37BIC11BN
		white - grey		XC37BIC11BGN
		beige - tobacco		XC37BEC11BN
		beige - ardesia		XC37BEC11BGN
<h2>48</h2> <p>4,00 x 8,00 h.1,20 m (4,40 x 8,40)</p>	 <p>10 M³ H DE AREIA 1 SKIMMER 1 SKIMMER 10 m³ h SAND FILTERING SYSTEM</p>	white - tobacco		XC48BIS10BN
		white - ardesia		XC48BIS10BGN
		beige - tobacco		XC48BES10BN
		beige - ardesia		XC48BES10BGN
<h2>49</h2> <p>4,00 x 9,00 h.1,20 m (4,40 x 9,40)</p>	 <p>15 M³ H DE AREIA 2 SKIMMERS 2 SKIMMERS 15 m³ h SAND FILTERING SYSTEM</p>	white - tobacco		XC49BIS15BN
		white - ardesia		XC49BIS15BGN
		beige - tobacco		XC49BES15BN
		beige - ardesia		XC49BES15BGN

ATENÇÃO: As tonalidades das cores podem variar. ATTENTION: Colour shades may vary.

ACESSÓRIOS

ACCESSORIES

OPCIONAL

ACESSÓRIOS
ACCESSORIES

2 years
WARRANTY

KIT DE BASE PARA MONTAGEM SEM BASE DE CIMENTO

STEEL BASEMENT STRUCTURE FOR ASSEMBLY WITHOUT CONCRETE SLAB

OPCIONAL

O QUE É?

É a solução ideal para instalar a DolceVita sem obras de construção civil. Este acessório é colocado entre o fundo da piscina e o terreno devidamente preparado.

É constituído por tubos e chapas de aço específicos, galvanizados e revestidos a pó, que mantêm a lâmina da piscina elevada acima do solo. O enchimento posterior da estrutura de base com areia cria uma superfície de distribuição adequada para a carga acima da piscina.

QUAIS SÃO AS VANTAGENS?

O kit de base permite a instalação da DolceVita mesmo em zonas onde, devido a regulamentações especiais, não é permitida a utilização de betão.

Também é adequado para instalar a DolceVita como piscina temporária, uma vez que pode ser totalmente desmontada e, por conseguinte, tem um impacto ambiental nulo. Um certificado de mobilidade especial pode ser fornecido a pedido.

O kit de base é montado no local, tal como a estrutura da piscina DolceVita, e pode, por conseguinte, ser instalado em zonas de difícil acesso.

QUANDO É QUE O POSSO INSTALAR?

O kit de rodapé pode ser instalado em qualquer tipo de terreno, sujeito a verificação pelo seu engenheiro de projeto quanto à melhor forma de preparar o terreno para a montagem.

Ver o Manual de Montagem DolceVita para mais informações sobre a preparação do terreno.

WHAT IS IT ?

It is the perfect solution for installing DolceVita without any civil works. This accessory is positioned between the bottom of the pool and a suitably prepared ground.

It consists of specific galvanised powder-coated steel tubes and sheets that keep the pool liner elevated above the ground.

The subsequent filling of the base structure with sand creates an adequate distribution surface for the pool load above it.

WHAT ARE THE BENEFITS ?

The basement kit permits to install DolceVita in areas where the use of concrete is not allowed.

It is also suitable for installing DolceVita as a temporary pool as it can be totally dismantled with zero environmental impact. A specific mobility certificate can be provided on request.

The base kit is assembled on site, like the DolceVita pool structure. For this reason it can be installed in hard-to-reach areas as well.

WHEN CAN I INSTALL IT ?

The basement kit can be installed on any type of ground. It is strictly recommended to ask your design engineer to verify how to prepare the ground for installation at the best.

See DolceVita assembly instructions for more information on ground preparation.



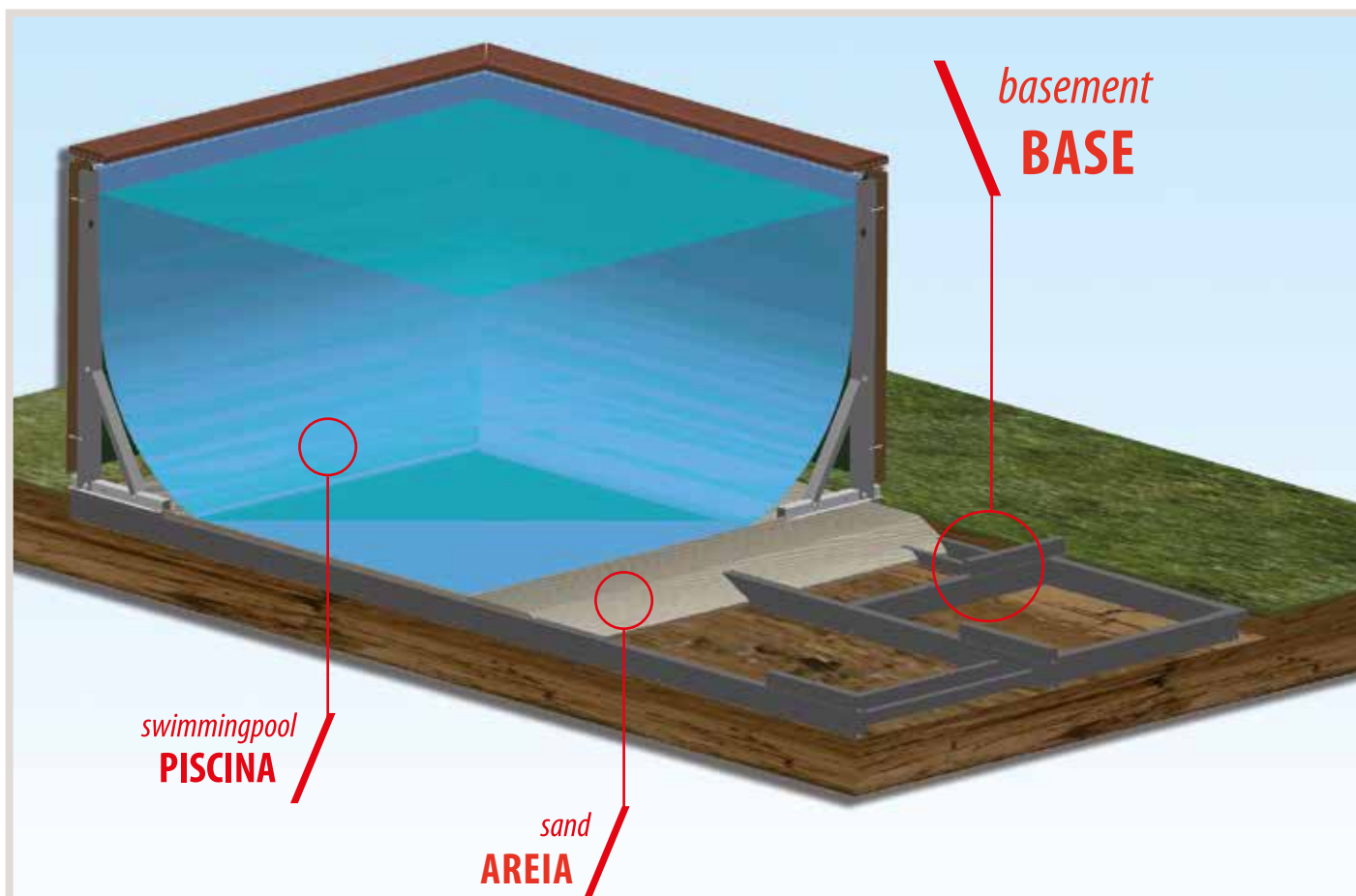

- zero impact installation
instalação de impacto zero
- easy to move and assemble
fácil de transportar e montar
- for installation where no concrete slab can be made
para montagem quando não é possível preparar uma laje de betão armado
- totally removable
totalmente desmontável

SPECCHIO ACQUA WATER SIZE	DESCRIZIONE - DESCRIPTION	CODICE - CODE
24*	KIT PREFABBRICATO IN ACCIAIO PER MONTAGGIO SENZA SOLETTA IN C.A. STEEL BASEMENT STRUCTURE FOR ASSEMBLY WITHOUT CONCRETE SLAB	JDVC24KITTB
25*	KIT PREFABBRICATO IN ACCIAIO PER MONTAGGIO SENZA SOLETTA IN C.A. STEEL BASEMENT STRUCTURE FOR ASSEMBLY WITHOUT CONCRETE SLAB	JDVC25KITTB
35	KIT PREFABBRICATO IN ACCIAIO PER MONTAGGIO SENZA SOLETTA IN C.A. STEEL BASEMENT STRUCTURE FOR ASSEMBLY WITHOUT CONCRETE SLAB	JDVC35KITTB
36	KIT PREFABBRICATO IN ACCIAIO PER MONTAGGIO SENZA SOLETTA IN C.A. STEEL BASEMENT STRUCTURE FOR ASSEMBLY WITHOUT CONCRETE SLAB	JDVC36KITTB
37	KIT PREFABBRICATO IN ACCIAIO PER MONTAGGIO SENZA SOLETTA IN C.A. STEEL BASEMENT STRUCTURE FOR ASSEMBLY WITHOUT CONCRETE SLAB	JDVC37KITTB
48	KIT PREFABBRICATO IN ACCIAIO PER MONTAGGIO SENZA SOLETTA IN C.A. STEEL BASEMENT STRUCTURE FOR ASSEMBLY WITHOUT CONCRETE SLAB	JDVC48KITTB
49	KIT PREFABBRICATO IN ACCIAIO PER MONTAGGIO SENZA SOLETTA IN C.A. STEEL BASEMENT STRUCTURE FOR ASSEMBLY WITHOUT CONCRETE SLAB	JDVC49KITTB
510	KIT PREFABBRICATO IN ACCIAIO PER MONTAGGIO SENZA SOLETTA IN C.A. STEEL BASEMENT STRUCTURE FOR ASSEMBLY WITHOUT CONCRETE SLAB	JDVC510KITTB

*TAMANHO DISPONÍVEL ENQUANTO DURAREM OS STOCKS. SIZE AVAILABLE WHILE STOCKS LAST.

KIT FIXAÇÃO ALINHAMENTO > ALIGNMENT FIXING KIT

O QUE É?

O kit é composto por peças de fixação em aço inoxidável AISI 304, incluindo parafusos, para evitar o STANDARD assentamento estrutural (desalinhamento) da Dolcevita durante a fase de enchimento da piscina.

QUAIS SÃO AS VANTAGENS?

Este kit simplifica e acelera a montagem da Dolcevita, uma vez que já não será necessário proceder à regulação após o enchimento, como STANDARDmente se faz sem a utilização deste acessório.

É sempre útil, mas torna-se indispensável quando um dos lados da banheira não está acessível ao operador para regular as várias alturas e inclinações da estrutura (por exemplo, no caso da Dolcevita estar encostada a uma parede ou num espaço confinado).

QUANDO É QUE O POSSO INSTALAR?

A montagem do kit de fixação e de alinhamento já está prevista e preparada desde a versão reforçada versão 2014 da Dolcevita.

Não pode ser montado em banheiras já instaladas (sem a sua desmontagem completa), pois é necessário destacar o pé da laje para apertar os parafusos de fixação.

O kit é adaptável às estruturas Dolcevita anteriores à versão 2014, apenas desmontando completamente a estrutura e efetuando os furos específicos no local.



WHAT IS IT ?

The alignment fixing kit is an AISI 304 stainless steel locking system. It consists of fasteners that prevent the normal structural misalignment of Dolcevita during the filling phase.

WHAT ARE THE BENEFITS ?

This kit simplifies and speeds up Dolcevita assembly, as it won't be necessary to adjust the pool after filling with water. It's installation becomes essential if one side of Dolcevita is not accessible to the operator when adjusting the heights and slopes of the structure (e.g. when Dolcevita is installed against a wall, or in a confined space).

WHEN CAN I INSTALL IT ?

It fits with Dolcevita structures produced from April 2014 on, without any modification.

You can't add the kit to an assembled pool, unless you dismantle the pool completely.

The alignmet fixing kit can be adapted also to Dolcevita structures purchased before April 2014. In this case the structure of the pool should be modified on site.

ESPELHO DE ÁGUA WATER SIZE	DESCRIÇÃO - DESCRIPTION	CÓDIGO - CODE
24	KIT DE PEÇAS EM AÇO INOXIDÁVEL PARA ESTABILIZAR A ESTRUTURA DO TANQUE VAZIO STAINLESS STEEL COMPONENTS TO STABILIZE THE STRUCTURE OF THE POOL.TO ASSEMBLE ONLY WHEN THE POOL IS EMPTY	JDV24KITAL
25	KIT DE PEÇAS EM AÇO INOXIDÁVEL PARA ESTABILIZAR A ESTRUTURA DO TANQUE VAZIO STAINLESS STEEL COMPONENTS TO STABILIZE THE STRUCTURE OF THE POOL.TO ASSEMBLE ONLY WHEN THE POOL IS EMPTY	JDV25KITAL
35	KIT DE PEÇAS EM AÇO INOXIDÁVEL PARA ESTABILIZAR A ESTRUTURA DO TANQUE VAZIO STAINLESS STEEL COMPONENTS TO STABILIZE THE STRUCTURE OF THE POOL.TO ASSEMBLE ONLY WHEN THE POOL IS EMPTY	JDV35KITAL
36	KIT DE PEÇAS EM AÇO INOXIDÁVEL PARA ESTABILIZAR A ESTRUTURA DO TANQUE VAZIO STAINLESS STEEL COMPONENTS TO STABILIZE THE STRUCTURE OF THE POOL.TO ASSEMBLE ONLY WHEN THE POOL IS EMPTY	JDV36KITAL
37	KIT DE PEÇAS EM AÇO INOXIDÁVEL PARA ESTABILIZAR A ESTRUTURA DO TANQUE VAZIO STAINLESS STEEL COMPONENTS TO STABILIZE THE STRUCTURE OF THE POOL.TO ASSEMBLE ONLY WHEN THE POOL IS EMPTY	JDV37KITAL
48	KIT DE PEÇAS EM AÇO INOXIDÁVEL PARA ESTABILIZAR A ESTRUTURA DO TANQUE VAZIO STAINLESS STEEL COMPONENTS TO STABILIZE THE STRUCTURE OF THE POOL.TO ASSEMBLE ONLY WHEN THE POOL IS EMPTY	JDV48KITAL
49	KIT DE PEÇAS EM AÇO INOXIDÁVEL PARA ESTABILIZAR A ESTRUTURA DO TANQUE VAZIO STAINLESS STEEL COMPONENTS TO STABILIZE THE STRUCTURE OF THE POOL.TO ASSEMBLE ONLY WHEN THE POOL IS EMPTY	JDV49KITAL
510	KIT DE PEÇAS EM AÇO INOXIDÁVEL PARA ESTABILIZAR A ESTRUTURA DO TANQUE VAZIO STAINLESS STEEL COMPONENTS TO STABILIZE THE STRUCTURE OF THE POOL.TO ASSEMBLE ONLY WHEN THE POOL IS EMPTY	JDV510KITAL

OPCIONAL

MODELO DE TRAÇADO > TRACING TEMPLATE

O QUE É?

Uma ferramenta útil e versátil que, durante a montagem, permite ao operador dispor de um mapa preciso dos pontos de perfuração da laje e da posterior cravação.

WHAT IS IT ?

It is a useful tool for the operator, giving him a precise map of the points to drill on the slab and then dowel.

IMAGEM - PICTURE	DESCRIÇÃO - DESCRIPTION	CÓDIGO - CODE
	MODELO DE TRAÇADO PARA DOLCEVITA (E DOLCEVITA GOLD E BLUESPRING) TRACING TEMPLATE FOR DOLCEVITA (DOLCEVITA GOLD AND BLUESPRING) POOL	JDVMODINA

KIT DE NATAÇÃO EM CONTRACORRENTE COUNTERCURRENT SWIMMING KIT

OPCIONAL

O QUE É?

O Kit Natação Contracorrente é um acessório composto por duas bombas de 1560W cada uma (caudal máximo 36 m³/h, altura manométrica 12,8 m), quatro passagens de aspiração com grelha de proteção, 2 bocais NCC com flanges específicas para montagem nos revestimentos DolceVita, bem como os acessórios e tubagens necessários para colocar a bomba a 3,5 m da piscina, conforme exigido pelas normas de segurança.

O kit inclui o interruptor pneumático para ligar e um painel de controlo específico para controlar e temporizar as bombas.

QUAIS SÃO AS VANTAGENS?

Este acessório de alto desempenho para nadar contra a corrente foi criado especialmente para a Piscine Laghetto, é fácil de instalar e permite nadar mesmo em piscinas pequenas.

QUANDO É QUE O POSSO INSTALAR?

Apenas disponível para os modelos DolceVita Diva e Diva LTI.

Para as piscinas com uma largura de 3 ou 4 m.

A posição standard do acessório na piscina não pode ser alterada (ver esquema ao lado).

Acessório a encomendar apenas em conjunto com o kit de piscina no qual vai ser instalado.

Não pode ser encomendado posteriormente.



WHAT IS IT ?

The countercurrent swimming kit consists of two 1560W pumps (max. flow rate 36 m³/h, head 12.8 m), four suction fittings with protection grid, two nozzles with specific flanges for installation on DolceVita liners, fittings and piping to place the pump at a distance of 3,5 m from the pool.

A pneumatic switch is included in the kit, as well as a specific switchboard for pump control and timing.

WHAT ARE THE BENEFITS ?

This high-performance accessory for swimming against the current has been specially studied for Piscine Laghetto. It can be easily installed and gives you the possibility to swim even in small pools.

WHEN CAN I INSTALL IT ?

You can install it only on DolceVita Diva and Diva LTI models.

It is studied for pools with a width of 3 or 4 m.

It can be installed only in the standard position shown in the diagram next page.

It can be ordered only together with the pool kit where it will be installed.

It cannot be ordered later.

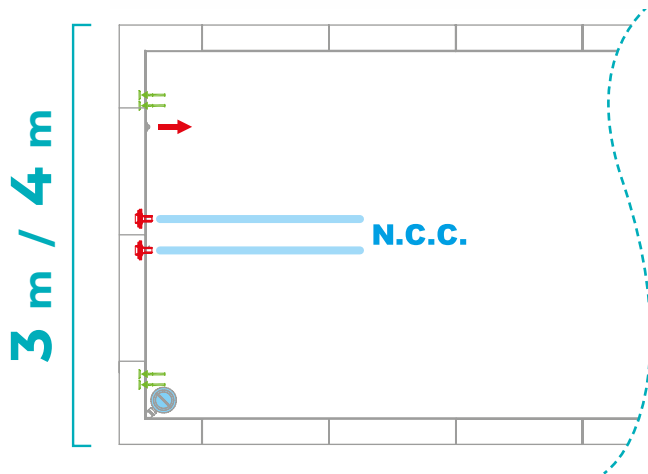

 **POSIÇÃO PADRÃO DO ACESSÓRIO**
Exemplo genérico em relação à posição do skimmer

ACCESSORY STANDARD POSITION
in relation to the position of the skimmer.

	DESCRIÇÃO - DESCRIPTION	CÓDIGO - CODE
3 m.	<p>KIT DE PISCINA - PISCINA CURTO LADO COMPRIMENTO 3 M. N. 2 MOTORES, N. 2 JATOS DE ÁGUA, TUBAGEM, QUADRO ELÉTRICO E CONTROLO REMOTO COM FIO.</p> <p>COUNTERCURRENT SWIMMING KIT FOR POOL WIDTH 3 M 2 MOTORS, 2 WATER JETS, PIPING, SWITCHBOARD AND WIRED REMOTE CONTROL.</p>	JDVKITNCC030
4 m.	<p>KIT DE PISCINA - PISCINA CURTO LADO COMPRIMENTO 3 M. N. 2 MOTORES, N. 2 JATOS DE ÁGUA, TUBAGEM, QUADRO ELÉTRICO E CONTROLO REMOTO COM FIO.</p> <p>COUNTERCURRENT SWIMMING KIT FOR POOL WIDTH 4 M 2 MOTORS, 2 WATER JETS, PIPING, SWITCHBOARD AND WIRED REMOTE CONTROL.</p>	JDVKITNCC040

ATENÇÃO: PARA ESTE ACESSÓRIO, É NECESSÁRIO ACRESCENTAR O SEGUINTE CÓDIGO À SUA ENCOMENDA
ATTENTION: FOR THESE ACCESSORIES, PLEASE ALSO ADD TO THE ORDER THE FOLLOWING CODE.

	<p>PERFURAÇÃO ESPECIAL DA LÂMINA PARA O ACESSÓRIO A INSTALAR SPECIAL DRILLING OF THE LINER FOR THE ACCESSORY TO BE INSTALLED</p>	JFOROFS
--	--	----------------

KIT DE HIDROMASSAGEM DE 7 JATOS

7-JET HYDROMASSAGE KIT

OPCIONAL

O QUE É?

O "kit hidromassagem" é composto por uma bomba de 900 W (caudal máximo 18m³/h, altura manométrica 13,5 m), duas passagens de aspiração com grelha de proteção, 7 bocais de hidromassagem com flanges específicas para montagem nos revestimentos Dolcevita, acessórios e tubagens necessários para colocar a bomba a 3,5 m da piscina (conforme exigido pelas normas de segurança). O kit inclui o interruptor pneumático para a ligação e um quadro elétrico específico para o controlo e a temporização da bomba.

O kit inclui o interruptor pneumático para ligar e um painel de controlo específico para controlar e temporizar a bomba.

QUAIS SÃO AS VANTAGENS?

Este acessório de alto desempenho foi especialmente concebido para responder à procura cada vez maior de soluções de bem-estar para a piscina.

O kit de hidromassagem completa a Dolcevita criando um canto dedicado.

QUANDO É QUE O POSSO INSTALAR?

Disponível para Dolcevita apenas para os modelos Ratã, Diva e Diva LTI.

Para as piscinas com uma largura de 3 ou 4 m.

A posição standard do acessório na piscina não pode ser alterada (ver esquema ao lado).

O acessório só pode ser encomendado em conjunto com o kit de piscina no qual vai ser instalado.

Não pode ser encomendado posteriormente.



WHAT IS IT ?

The hydromassage kit is composed of a 900W pump (max. flow rate 18 m³/h, head 13.5 m), two suction fittings with protection grid, seven hydro jets with specific flanges for Dolcevita liners, fittings and piping to place the pump at a distance of 3,5 m from the pool

A pneumatic switch is included in the kit as well as a dedicated switchboard for pump control and timing.

WHAT ARE THE BENEFITS ?

The high-performance hydromassage kit has been specifically designed to integrate wellness solutions in the pool.

It finishes Dolcevita creating a dedicated corner.

WHEN CAN I INSTALL IT ?

You can install it on Dolcevita Rattan, Diva and Diva LTI models.

It is studied for pools with a width of 3 or 4 m.

It can be installed only in the standard position shown in the diagram next page.

It can be ordered only together with the pool kit where it will be installed.

It cannot be ordered later.



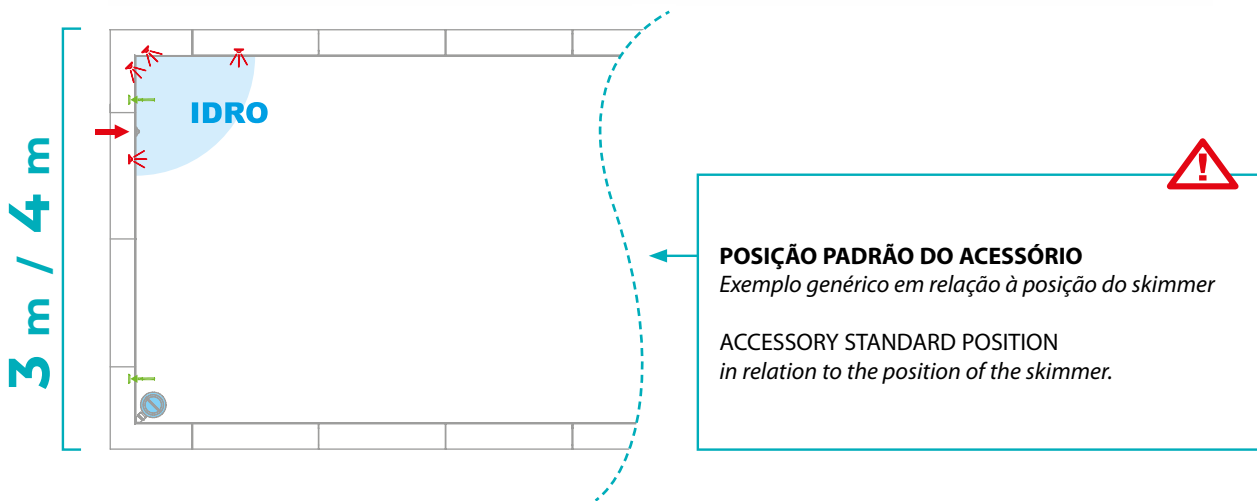
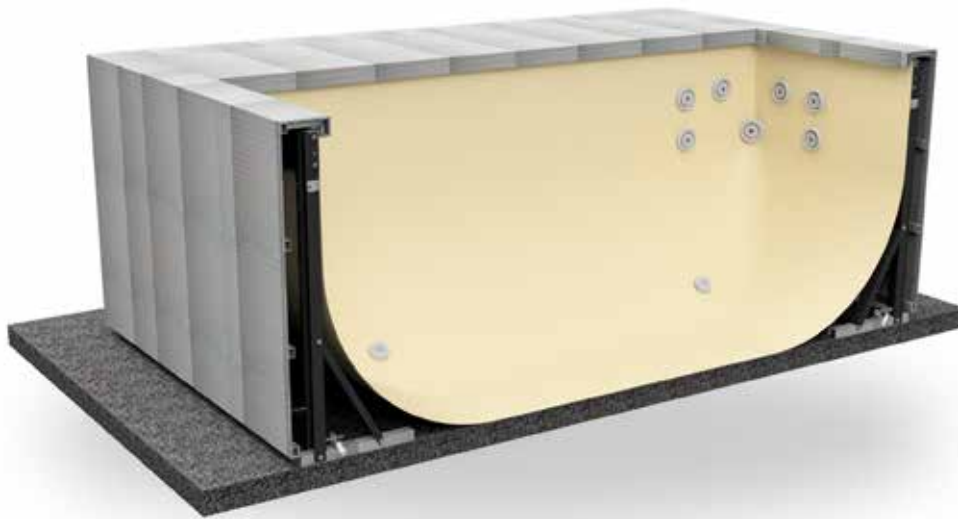

	DESCRIÇÃO - DESCRIPTION	CÓDIGO - CODE
3 m.	<p>KIT DE HIDROMASSAGEM DE 7 JATOS - PISCINA 3 M LARGURA N. 1 MOTOR, N. 7 BICOS, QUADRO ELÉTRICO E CONTROLO REMOTO COM FIO TEMPORIZADO.</p> <p>7 JETS HYDROMASSAGE KIT - SWIMMING POOL WIDTH 3 M 1 MOTOR, 7 NOZZLES, SWITCHBOARD AND TIMED WIRED REMOTE CONTROL.</p>	JDVKITIDR0030
4 m.	<p>KIT DE HIDROMASSAGEM DE 7 JATOS - PISCINA 3 M LARGURA N. 1 MOTOR, N. 7 BICOS, QUADRO ELÉTRICO E CONTROLO REMOTO COM FIO TEMPORIZADO.</p> <p>7 JETS HYDROMASSAGE KIT - SWIMMING POOL WIDTH 4 M 1 MOTOR, 7 NOZZLES, SWITCHBOARD AND TIMED WIRED REMOTE CONTROL.</p>	JDVKITIDR0040

ATENÇÃO: PARA ESTE ACESSÓRIO, É NECESSÁRIO ACRESCENTAR O SEGUINTE CÓDIGO À SUA ENCOMENDA
ATTENTION: FOR THESE ACCESSORIES, PLEASE ALSO ADD TO THE ORDER THE FOLLOWING CODE.



PERFURAÇÃO ESPECIAL DA LÂMINA PARA O ACESSÓRIO A INSTALAR
SPECIAL DRILLING OF THE LINER FOR THE ACCESSORY TO BE INSTALLED

JFOROFS

COBERTURA DE INVERNO DOLCEVITA WINTER POOL COVER FOR DOLCEVITA

OPCIONAL

O QUE É?

A cobertura de inverno Light System Plus com tirantes elásticos, de cor verde/preta, permite fechar hermeticamente a piscina durante os meses em que esta não é utilizada.

A utilização da cobertura de piscina, com a utilização dos produtos químicos corretos, permite a boa conservação da água da piscina.

WHAT IS IT ?

The pool winter cover "Light System Plus" (in green/black colors) is equipped with elastic cords rod that allow to close hermetically the pool when not in use.

This accessory, jointly with correct chemical products, preserves the water status during winter period.

ESPELHO DE ÁGUA WATER SIZE	TAMANHO DA LONA FINISHED COVER SIZE	DESCRIÇÃO DESCRIPTION	CÓDIGO CODE
24	3,20 x 5,20 m.	COBERTURA DE INVERNO LSP COM TIRANTES ELÁSTICOS PARA DOLCEVITA ACIMA DO SOLO LSP WINTER COVER COMPLETE WITH ELASTIC CORDS AND FIXATIONS	JCODVC24GG
25	3,20 x 6,20 m.	COBERTURA DE INVERNO LSP COM TIRANTES ELÁSTICOS PARA DOLCEVITA ACIMA DO SOLO LSP WINTER COVER COMPLETE WITH ELASTIC CORDS AND FIXATIONS	JCODVC25GG
35	4,20 x 6,20 m.	COBERTURA DE INVERNO LSP COM TIRANTES ELÁSTICOS PARA DOLCEVITA ACIMA DO SOLO LSP WINTER COVER COMPLETE WITH ELASTIC CORDS AND FIXATIONS	JCODVC35GG
36	4,20 x 7,20 m.	COBERTURA DE INVERNO LSP COM TIRANTES ELÁSTICOS PARA DOLCEVITA ACIMA DO SOLO LSP WINTER COVER COMPLETE WITH ELASTIC CORDS AND FIXATIONS	JCODVC36GG
37	4,20 x 8,20 m.	COBERTURA DE INVERNO LSP COM TIRANTES ELÁSTICOS PARA DOLCEVITA ACIMA DO SOLO LSP WINTER COVER COMPLETE WITH ELASTIC CORDS AND FIXATIONS	JCODVC37GG
48	5,20 x 9,20 m.	COBERTURA DE INVERNO LSP COM TIRANTES ELÁSTICOS PARA DOLCEVITA ACIMA DO SOLO LSP WINTER COVER COMPLETE WITH ELASTIC CORDS AND FIXATIONS	JCODVC48GG
49	5,20 x 10,20 m.	COBERTURA DE INVERNO LSP COM TIRANTES ELÁSTICOS PARA DOLCEVITA ACIMA DO SOLO LSP WINTER COVER COMPLETE WITH ELASTIC CORDS AND FIXATIONS	JCODVC49GG
510	6,20 x 11,20 m.	COBERTURA DE INVERNO LSP COM TIRANTES ELÁSTICOS PARA DOLCEVITA ACIMA DO SOLO LSP WINTER COVER COMPLETE WITH ELASTIC CORDS AND FIXATIONS	JCODVC510GG
LTI 35	4,20 x 7,00 m.	CAPA DE INVERNO LSP COM PUXADORES ELÁSTICOS PARA DOLCEVITA DIVA STI LSP WINTER COVER COMPLETE WITH ELASTIC CORDS AND FIXATIONS FOR DOLCEVITA DIVA LTI	JCODVC35DGGG
LTI 36	4,20 x 8,00 m.	CAPA DE INVERNO LSP COM PUXADORES ELÁSTICOS PARA DOLCEVITA DIVA STI LSP WINTER COVER COMPLETE WITH ELASTIC CORDS AND FIXATIONS FOR DOLCEVITA DIVA LTI	JCODVC36DGGG
LTI 37	4,20 x 9,00 m.	CAPA DE INVERNO LSP COM PUXADORES ELÁSTICOS PARA DOLCEVITA DIVA STI LSP WINTER COVER COMPLETE WITH ELASTIC CORDS AND FIXATIONS FOR DOLCEVITA DIVA LTI	JCODVC37DGGG
LTI 48	5,20 x 10,00 m.	CAPA DE INVERNO LSP COM PUXADORES ELÁSTICOS PARA DOLCEVITA DIVA STI LSP WINTER COVER COMPLETE WITH ELASTIC CORDS AND FIXATIONS FOR DOLCEVITA DIVA LTI	JCODVC48DGGG
LTI 49	5,20 x 11,00 m.	CAPA DE INVERNO LSP COM PUXADORES ELÁSTICOS PARA DOLCEVITA DIVA STI LSP WINTER COVER COMPLETE WITH ELASTIC CORDS AND FIXATIONS FOR DOLCEVITA DIVA LTI	JCODVC49DGGG

COBERTURA DE VERÃO DOLCEVITA SUMMER POOL COVER FOR DOLCEVITA

OPCIONAL

O QUE É?

A cobertura isotérmica permite reduzir as trocas de calor dia/noite e conservar melhor a temperatura acumulada durante o dia.

Pode igualmente ser deixada a flutuar na água durante o dia, uma vez que o material permite a passagem da luz solar. Esta cobertura é fornecida com rebordo.

Esta cobertura é vendida com rebordo.

WHAT IS IT ?

The isothermal cover reduces the day/night heat exchange and helps to maintain the water temperature.

It can be left floating on the water during the day, because its fabric allows sunlight to pass through.

Isothermal cover for DolceVita is edged for a better finish.

ESPELHO DE ÁGUA WATER SIZE	TAMANHO DA LONA COVER TOTAL SIZE	DESCRIÇÃO DESCRIPTION	CÓDIGO CODE
24	2,00 x 4,00 m.	COBERTURA ISOTÉRMICA DE VERÃO PARA DOLCEVITA ISOTHERMAL SUMMER COVER FOR DOLCEVITA	JCOGIDV24GG
25	2,00 x 5,00 m.	COBERTURA ISOTÉRMICA DE VERÃO PARA DOLCEVITA ISOTHERMAL SUMMER COVER FOR DOLCEVITA	JCOGIDV25GG
35	3,00 x 5,00 m.	COBERTURA ISOTÉRMICA DE VERÃO PARA DOLCEVITA ISOTHERMAL SUMMER COVER FOR DOLCEVITA	JCOGIDV35GG
36	3,00 x 6,00 m.	COBERTURA ISOTÉRMICA DE VERÃO PARA DOLCEVITA ISOTHERMAL SUMMER COVER FOR DOLCEVITA	JCOGIDV36GG
37	3,00 x 7,00 m.	COBERTURA ISOTÉRMICA DE VERÃO PARA DOLCEVITA ISOTHERMAL SUMMER COVER FOR DOLCEVITA	JCOGIDV37GG
48	4,00 x 8,00 m.	COBERTURA ISOTÉRMICA DE VERÃO PARA DOLCEVITA ISOTHERMAL SUMMER COVER FOR DOLCEVITA	JCOGIDV48GG
49	4,00 x 9,00 m.	COBERTURA ISOTÉRMICA DE VERÃO PARA DOLCEVITA ISOTHERMAL SUMMER COVER FOR DOLCEVITA	JCOGIDV49GG
510	5,00 x 10,00 m.	COBERTURA ISOTÉRMICA DE VERÃO PARA DOLCEVITA ISOTHERMAL SUMMER COVER FOR DOLCEVITA	JCOGIDV510GG

ECRÃ DE SEGURANÇA PARA ESCADAS DE LUXO SAFETY SCREEN FOR LUXURY LADDER

OPCIONAL

O QUE É?

Este kit de segurança em plexiglas para a escada modelo Luxury impede que as crianças entrem na piscina sem a vigilância de um adulto.

WHAT IS IT ?

This plexiglass safety kit for the Luxury ladder prevents children from entering the pool when unsupervised by an adult.

IMAGEM - PICTURE	DESCRIÇÃO - DESCRIPTION	CÓDIGO - CODE
	ECRÃ DE SEGURANÇA EM PLEXIGLAS PARA ESCADAS DE LUXO PLEXIGLASS KIDS-SAFETY KIT FOR LUXURY LADDER	JSCDVKS

PESOS E MEDIDAS > WEIGHTS & SIZES

RATTAN

MODELO MODEL	SISTEMA DE FILTRAÇÃO FILTERING SYSTEM	CÓDIGO CODE	BANCO cm. PALLET	PESO Kg WEIGHT	N. BANCOS PALLET N°
24 RATTAN	1 SKIMMER 10 M³ H SAND FILTERING SYSTEM	XC24...S10R	100 x 140 x 240 h	357	1
	1 SKIMMER 11 M³ H CARTRIDGE FILTERING SYSTEM	XC24...C11R	100 x 140 x 240 h	330	1
25 RATTAN	1 SKIMMER 10 M³ H SAND FILTERING SYSTEM	XC25...S10R	100 x 140 x 240 h	386	1
	1 SKIMMER 11 M³ H CARTRIDGE FILTERING SYSTEM	XC25...C11R	100 x 140 x 240 h	360	1
35 RATTAN	1 SKIMMER 10 M³ H SAND FILTERING SYSTEM	XC35...S10R	100 x 140 x 240 h	432	1
	1 SKIMMER 11 M³ H CARTRIDGE FILTERING SYSTEM	XC35...C11R	100 x 140 x 240 h	410	1
36 RATTAN	1 SKIMMER 10 M³ H SAND FILTERING SYSTEM	XC36...S10R	100 x 140 x 240 h 100 x 120 x 110 h	565	2
	1 SKIMMER 11 M³ H CARTRIDGE FILTERING SYSTEM	XC36...C11R	100 x 140 x 240 h 100 x 120 x 90 h	520	2
37 RATTAN	1 SKIMMER 10 M³ H SAND FILTERING SYSTEM	XC37...S10R	100 x 140 x 240 h 100 x 120 x 135 h	575	2
	1 SKIMMER 11 M³ H CARTRIDGE FILTERING SYSTEM	XC37...C11R	100 x 140 x 240 h 100 x 120 x 100 h	565	2
48 RATTAN	1 SKIMMER 10 M³ H SAND FILTERING SYSTEM	KITDVC48...S10R	100 x 140 x 240 h 100 x 120 x 140 h	645	2
49 RATTAN	2 SKIMMERS 15 M³ H SAND FILTERING SYSTEM	XC49...S15R	100 x 140 x 240 h 100 x 120 x 150 h 100 x 120 x 160 h	720	3
510 RATTAN	2 SKIMMERS 15 M³ H SAND FILTERING SYSTEM	XC510...S15R	100 x 140 x 240 h 100 x 120 x 160 h 100 x 120 x 170 h	860	3

NOTA: Os pesos e medidas dos kits de piscina com filtro de areia referem-se a filtros com válvula superior.
NOTE: All the weights and sizes for sand filter pools kit are related to top-valve models.

DIVA

MODELO MODEL	SISTEMA DE FILTRAÇÃO FILTERING SYSTEM	CÓDIGO CODE	BANCO cm. PALLET	PESO Kg WEIGHT	N. BANCOS PALLET N°
24 DIVA	1 SKIMMER 10 M³ H SAND FILTERING SYSTEM	XC24...S10D	100 x 140 x 240 h 100 x 120 x 120 h	332	2
	1 SKIMMER 11 M³ H CARTRIDGE FILTERING SYSTEM	XC24...C11D	100 x 140 x 240 h 100 x 120 x 120 h	310	2
25 DIVA	1 SKIMMER 10 M³ H SAND FILTERING SYSTEM	XC25...S10D	100 x 140 x 240 h 100 x 120 x 120 h	356	2
	1 SKIMMER 11 M³ H CARTRIDGE FILTERING SYSTEM	XC25...C11D	100 x 140 x 240 h 100 x 120 x 110 h	330	2
35 DIVA	1 SKIMMER 10 M³ H SAND FILTERING SYSTEM	XC35...S10D	100 x 140 x 240 h 100 x 120 x 180 h	389	2
	1 SKIMMER 11 M³ H CARTRIDGE FILTERING SYSTEM	XC35...C11D	100 x 140 x 240 h 100 x 120 x 180 h	360	2
36 DIVA	1 SKIMMER 10 M³ H SAND FILTERING SYSTEM	XC36...S10D	100 x 140 x 240 h 100 x 120 x 180 h	435	2
	1 SKIMMER 11 M³ H CARTRIDGE FILTERING SYSTEM	XC36...C11D	100 x 140 x 240 h 100 x 120 x 180 h	415	2
37 DIVA	1 SKIMMER 10 M³ H SAND FILTERING SYSTEM	XC37...S10D	100 x 140 x 240 h 100 x 120 x 190 h	472	2
	1 SKIMMER 11 M³ H CARTRIDGE FILTERING SYSTEM	XC37...C11D	100 x 140 x 240 h 100 x 120 x 180 h	445	2
48 DIVA	1 SKIMMER 10 M³ H SAND FILTERING SYSTEM	XC48...S10D	100 x 140 x 250 h 100 x 120 x 200 h	636	2
49 DIVA	2 SKIMMERS 15 M³ H SAND FILTERING SYSTEM	XC49...S15D	100 x 140 x 240 h 100 x 120 x 130 h 100 x 120 x 150 h	680	3
510 DIVA	2 SKIMMERS 15 M³ H SAND FILTERING SYSTEM	XC510...S15D	100 x 120 x 170 h 100 x 120 x 170 h 100 x 140 x 220 h	750	3

NOTA: Os pesos e medidas dos kits de piscina com filtro de areia referem-se a filtros com válvula superior.
NOTE: All the weights and sizes for sand filter pools kit are related to top-valve models.

DIVA LTI

MODELO MODEL	SISTEMA DE FILTRAÇÃO FILTERING SYSTEM	CÓDIGO CODE	BANCO cm. PALLET	PESO Kg WEIGHT	N. BANCOS PALLET N°
35 DIVA LTI	1 SKIMMER 10 M³ H SAND FILTERING SYSTEM	XC35...S10DG	100 x 140 x 240 h 100 x 120 x 200 h	410	2
	1 SKIMMER 11 M³ H CARTRIDGE FILTERING SYSTEM	XC35...C11DG	100 x 140 x 240 h 100 x 120 x 200 h	374	2
36 DIVA LTI	1 SKIMMER 10 M³ H SAND FILTERING SYSTEM	XC36...S10DG	100 x 140 x 240 h 100 x 120 x 200 h	455	2
	1 SKIMMER 11 M³ H CARTRIDGE FILTERING SYSTEM	XC36...C11DG	100 x 140 x 240 h 100 x 120 x 200 h	425	2
37 DIVA LTI	1 SKIMMER 10 M³ H SAND FILTERING SYSTEM	XC37...S10DG	100 x 140 x 240 h 100 x 120 x 210 h	492	2
	1 SKIMMER 11 M³ H CARTRIDGE FILTERING SYSTEM	XC37...C11DG	100 x 140 x 240 h 100 x 120 x 210 h	465	2
48 DIVA LTI	1 SKIMMER 10 M³ H SAND FILTERING SYSTEM	XC48...S10DG	100 x 140 x 240 h 100 x 120 x 180 h 100 x 120 x 120 h	656	3
49 DIVA LTI	2 SKIMMERS 15 M³ H SAND FILTERING SYSTEM	XC49...S15DG	100 x 140 x 240 h 100 x 120 x 160 h 100 x 120 x 140 h	700	3

NAKED

24 NAKED	1 SKIMMER 10 M³ H SAND FILTERING SYSTEM	XC24...S10N	100 x 140 x 240 h	357	1
	1 SKIMMER 11 M³ H CARTRIDGE FILTERING SYSTEM	XC24...C11N	100 x 140 x 240 h	330	1
25 NAKED	1 SKIMMER 10 M³ H SAND FILTERING SYSTEM	XC25...S10N	100 x 140 x 240 h	386	1
	1 SKIMMER 11 M³ H CARTRIDGE FILTERING SYSTEM	XC25...C11N	100 x 140 x 240 h	360	1
35 NAKED	1 SKIMMER 10 M³ H SAND FILTERING SYSTEM	XC35...S10N	100 x 140 x 240 h	432	1
	1 SKIMMER 11 M³ H CARTRIDGE FILTERING SYSTEM	XC35...C11N	100 x 140 x 240 h	410	1
36 NAKED	1 SKIMMER 10 M³ H SAND FILTERING SYSTEM	XC36...S10N	100 x 140 x 240 h	565	1
	1 SKIMMER 11 M³ H CARTRIDGE FILTERING SYSTEM	XC36...C11N	100 x 140 x 240 h	520	1
37 NAKED	1 SKIMMER 10 M³ H SAND FILTERING SYSTEM	XC37...S10N	100 x 140 x 240 h	575	1
	1 SKIMMER 11 M³ H CARTRIDGE FILTERING SYSTEM	XC37...C11N	100 x 140 x 240 h	565	1
48 NAKED	1 SKIMMER 10 M³ H SAND FILTERING SYSTEM	XC48...S10N	100 x 140 x 240 h	645	1
49 NAKED	2 SKIMMERS 15 M³ H SAND FILTERING SYSTEM	XC49...S15N	100 x 140 x 240 h 100 x 120 x 130 h	720	2
510 NAKED	2 SKIMMERS 15 M³ H SAND FILTERING SYSTEM	XC510...S15N	100 x 140 x 240 h 100 x 120 x 130 h	860	2

NOTA: Os pesos e medidas dos kits de piscina com filtro de areia referem-se a filtros com válvula superior
NOTE: All the weights and sizes for sand filter pools kit are related to top-valve models.

KIT DE BASE PARA MONTAGEM SEM BETÃO

STEEL BASEMENT STRUCTURE FOR ASSEMBLY WITHOUT CONCRETE SLAB

MODELO MODEL	DESCRIÇÃO DESCRIPTION	CÓDIGO CODE	BANCO cm. PALLET	PESO Kg WEIGHT	N. BANCOS PALLET N°
KIT x 24	KIT PRÉ-FABRICADO EM AÇO PARA MONTAGEM SEM LAJE DE BETÃO ARMADO STEEL BASEMENT STRUCTURE FOR ASSEMBLY WITHOUT CONCRETE SLAB	JDVC24KITTB	80 x 125 x 50 h	152	1
KIT x 25	KIT PRÉ-FABRICADO EM AÇO PARA MONTAGEM SEM LAJE DE BETÃO ARMADO STEEL BASEMENT STRUCTURE FOR ASSEMBLY WITHOUT CONCRETE SLAB	JDVC25KITTB	80 x 125 x 75 h	181	1
KIT x 35	KIT PRÉ-FABRICADO EM AÇO PARA MONTAGEM SEM LAJE DE BETÃO ARMADO STEEL BASEMENT STRUCTURE FOR ASSEMBLY WITHOUT CONCRETE SLAB	JDVC35KITTB	80 x 180 x 50 h	215	1
KIT x 36	KIT PRÉ-FABRICADO EM AÇO PARA MONTAGEM SEM LAJE DE BETÃO ARMADO STEEL BASEMENT STRUCTURE FOR ASSEMBLY WITHOUT CONCRETE SLAB	JDVC36KITTB	80 x 180 x 60 h	252	1
KIT x 37	KIT PRÉ-FABRICADO EM AÇO PARA MONTAGEM SEM LAJE DE BETÃO ARMADO STEEL BASEMENT STRUCTURE FOR ASSEMBLY WITHOUT CONCRETE SLAB	JDVC37KITTB	80 x 180 x 70 h	289	1
KIT x 48	KIT PRÉ-FABRICADO EM AÇO PARA MONTAGEM SEM LAJE DE BETÃO ARMADO STEEL BASEMENT STRUCTURE FOR ASSEMBLY WITHOUT CONCRETE SLAB	JDVC48KITTB	80 x 180 x 100 h	350	1
KIT x 49	KIT PRÉ-FABRICADO EM AÇO PARA MONTAGEM SEM LAJE DE BETÃO ARMADO STEEL BASEMENT STRUCTURE FOR ASSEMBLY WITHOUT CONCRETE SLAB	JDVC49KITTB	80 x 180 x 120 h	387	1
KIT x 510	KIT PRÉ-FABRICADO EM AÇO PARA MONTAGEM SEM LAJE DE BETÃO ARMADO STEEL BASEMENT STRUCTURE FOR ASSEMBLY WITHOUT CONCRETE SLAB	JDVC510KITTB	80 x 180 x 155 h	578	1

KIT DE NATAÇÃO EM CONTRACORRENTE - SWIM SYSTEM

MODELO MODEL	DESCRIÇÃO DESCRIPTION	CÓDIGO CODE	BANCO cm. PALLET	PESO Kg WEIGHT	N. BANCOS PALLET N°
KIT x 3 m.	KIT DE NATAÇÃO EM CONTRACORRENTE SWIMMING AGAINST THE CURRENT KIT	JDVKITNCC030	100 x 120 x 100 h	50	1
KIT x 4 m.	KIT DE NATAÇÃO EM CONTRACORRENTE SWIMMING AGAINST THE CURRENT KIT	JDVKITNCC040	100 x 120 x 110 h	60	1

KIT DE HIDROMASSAGEM DE 7 JATOS - 7 JETS HYDROMASSAGE KIT

MODELO MODEL	DESCRIÇÃO DESCRIPTION	CÓDIGO CODE	BANCO cm. PALLET	PESO Kg WEIGHT	N. BANCOS PALLET N°
KIT x 3 m.	KIT DE HIDROMASSAGEM DE 7 JATOS 7 JETS HYDROMASSAGE KIT	JDVKITIDR0030	80 x 120 x 50 h	30	1
KIT x 4 m.	KIT DE HIDROMASSAGEM DE 7 JATOS 7 JETS HYDROMASSAGE KIT	JDVKITIDR0040	80 x 120 x 60 h	35	1

DIMENSÕES DA PLATEIA PARA DOLCEVITA (escluída DIVA LTI) BASEMENT SIZES (NOT FOR DOLCEVITA DIVA LTI)

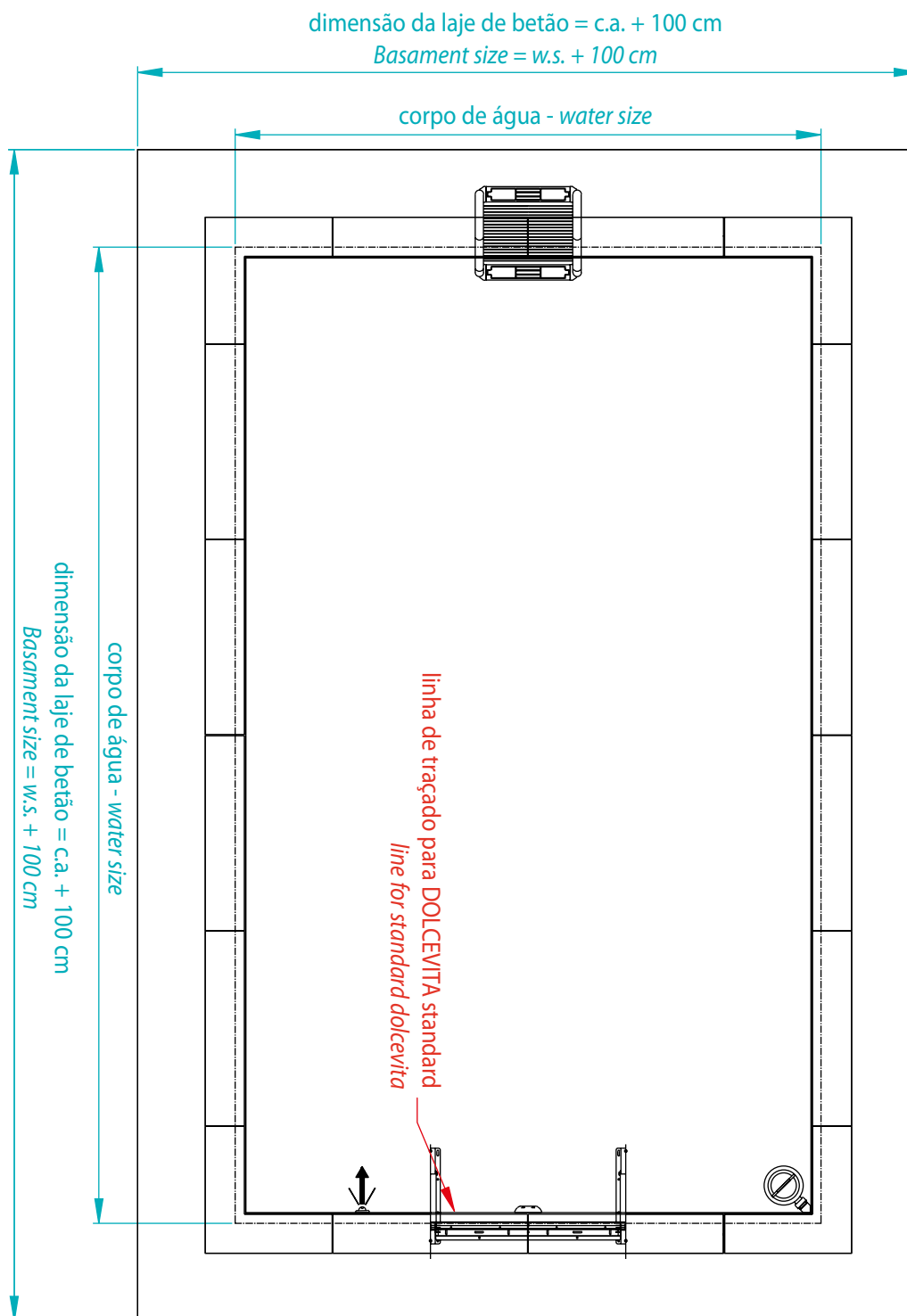

DIMENSÕES DA PLATEIA PARA DOLCEVITA DIVA LTI

BASEMENT SIZES FOR DOLCEVITA DIVA LTI

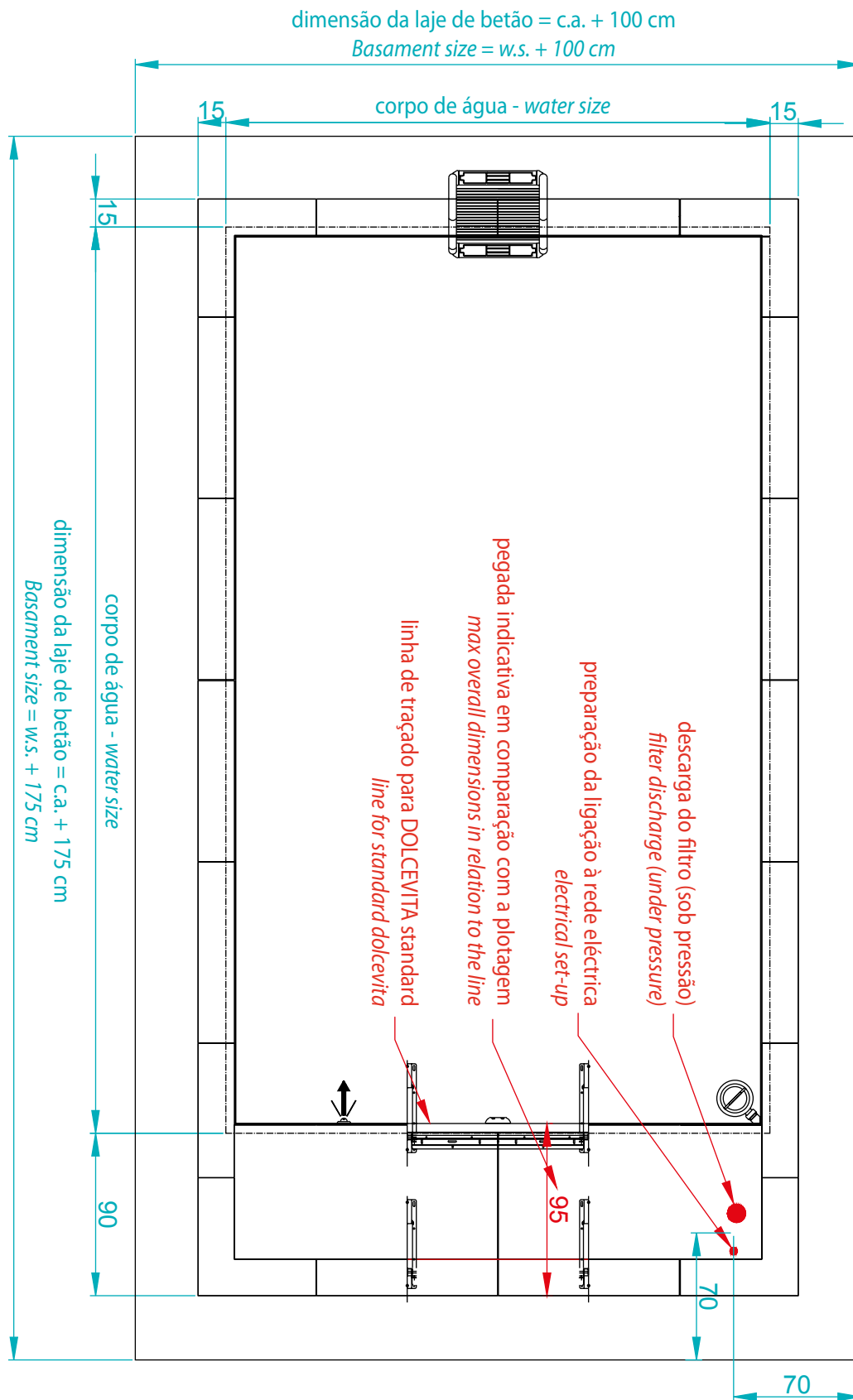

CARACTERÍSTICAS DAS OBRAS CIVIS

CONCRETE BASE

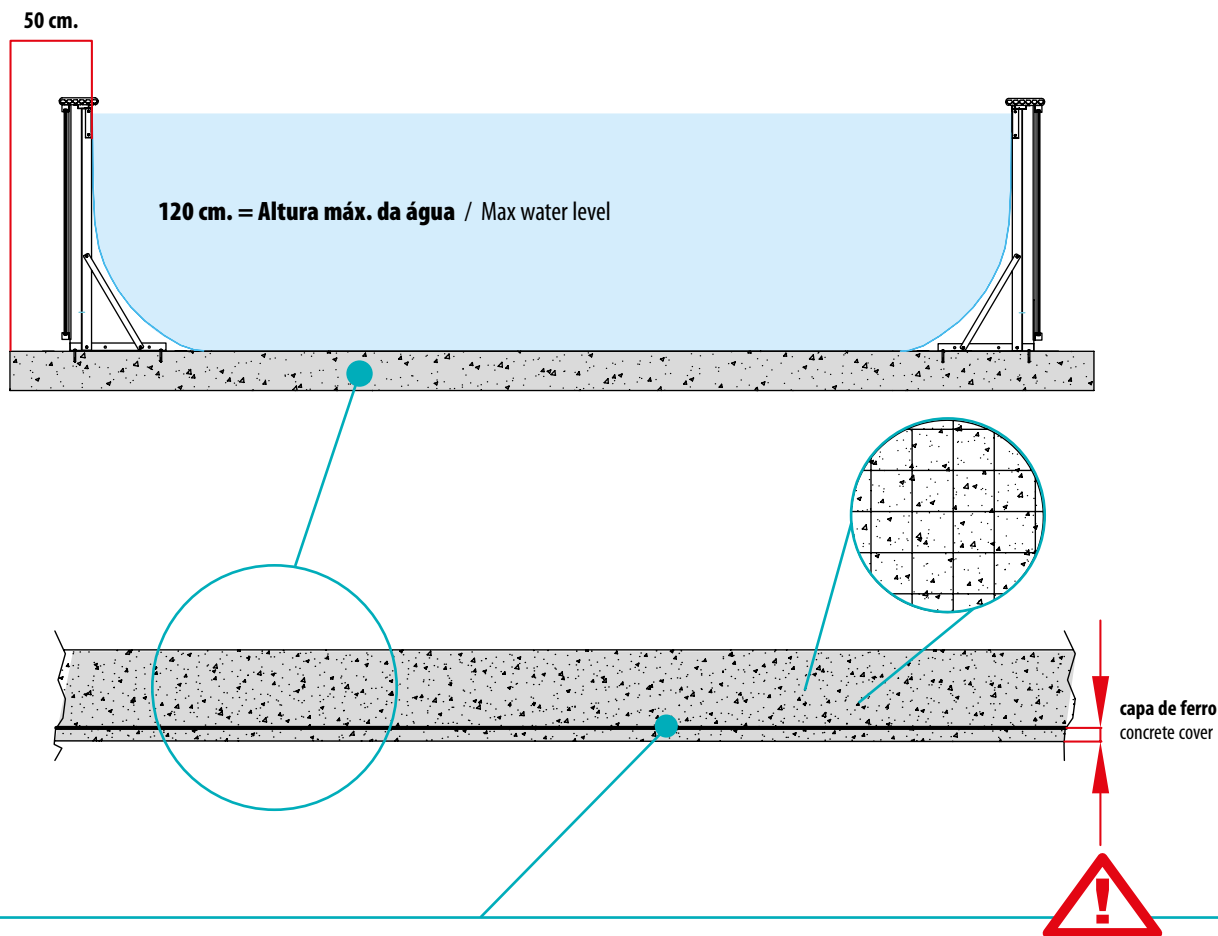

Consulte o seu engenheiro para obter as especificações ideais para a sua instalação

Check with your engineer which are the optimal requirements for your installation

Verificar se a laje é efetivamente retangular com diagonais iguais

Check the basement is really rectangular with the same diagonals

Verificar, em caso de terreno instável ou de deslizamento de terras, com conhecimentos geológicos, a viabilidade da laje

Check the basement is achievable in case of unstable ground by geological expertise

A superfície da peça fundida deve ser acabada e alisada sem imperfeições

The basement surface must be smooth without imperfections

Tolerância de desvio do plano do perímetro de fundição = ± 1 cm.

Tolerance gradient of the perimeter of slab = ± 1 cm.

ACESSÓRIOS DE POSIÇÃO STANDARD SKIMMER, FORNECIMENTO E Faro LED

STANDARD ACCESSORIES POSITION - SKIMMER, INLET AND LIGHT

24

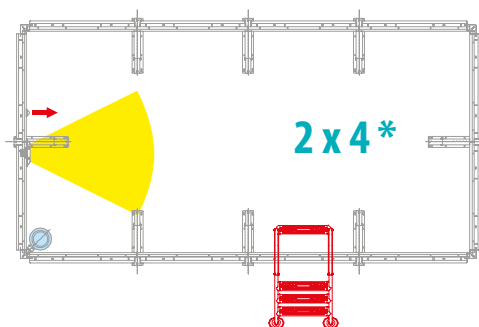

25

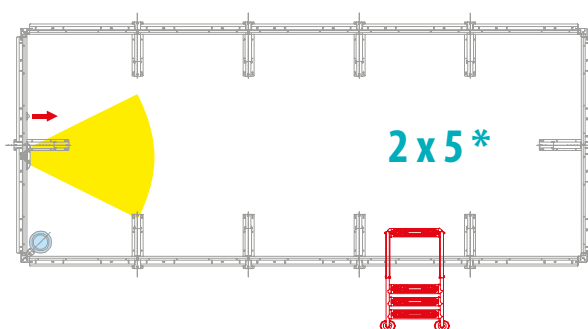

35

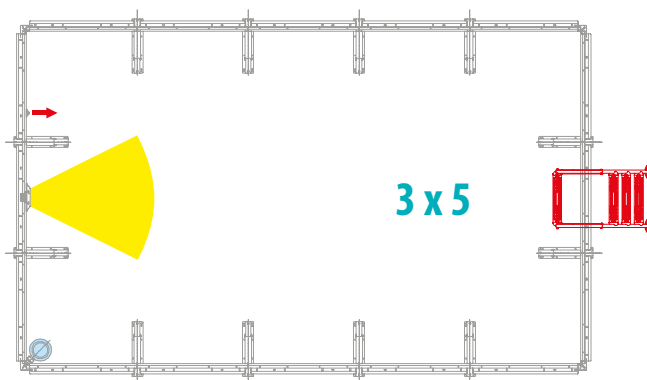

36

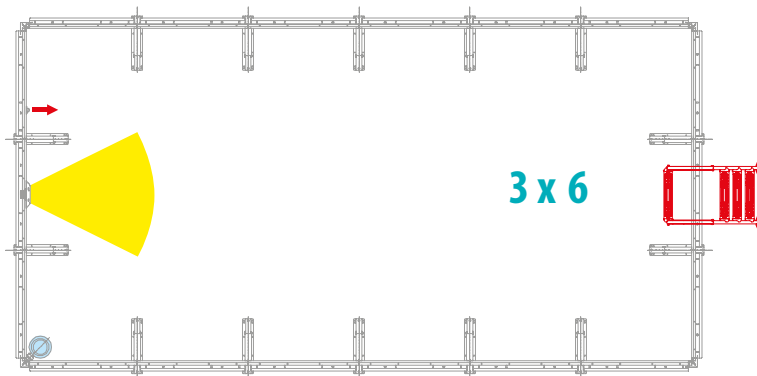

PARA ESTAS DIMENSÕES, NÃO É POSSÍVEL COLOCAR A ESCADA NO CENTRO DO LADO CURTO
* this sizes don't allow to place the ladder in the center of the short side

37

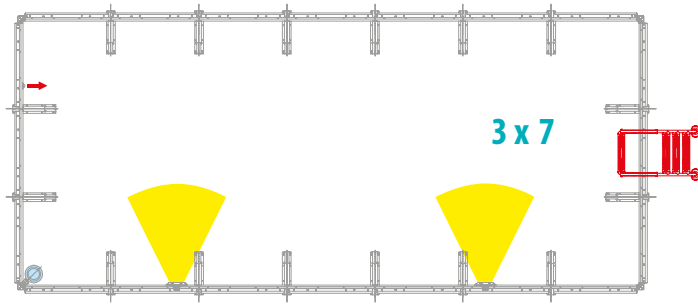

48

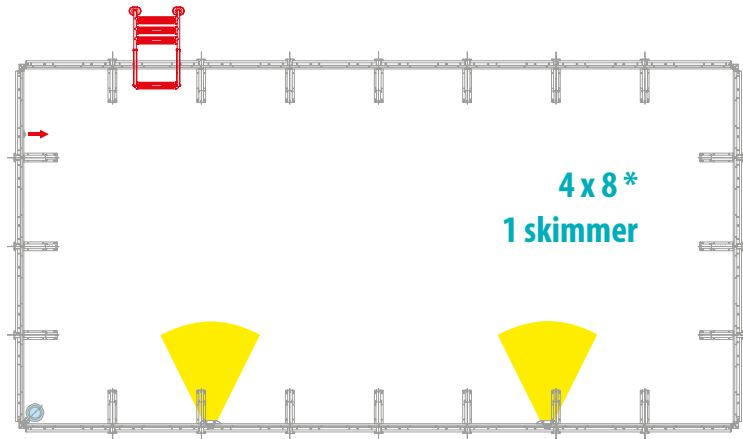

49

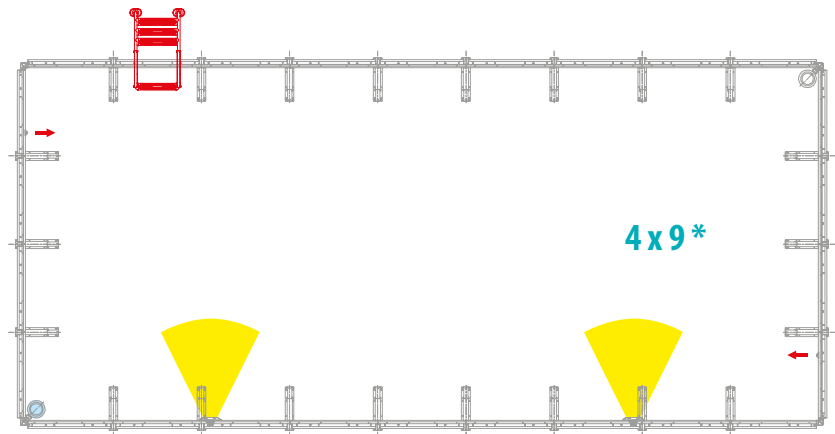

510

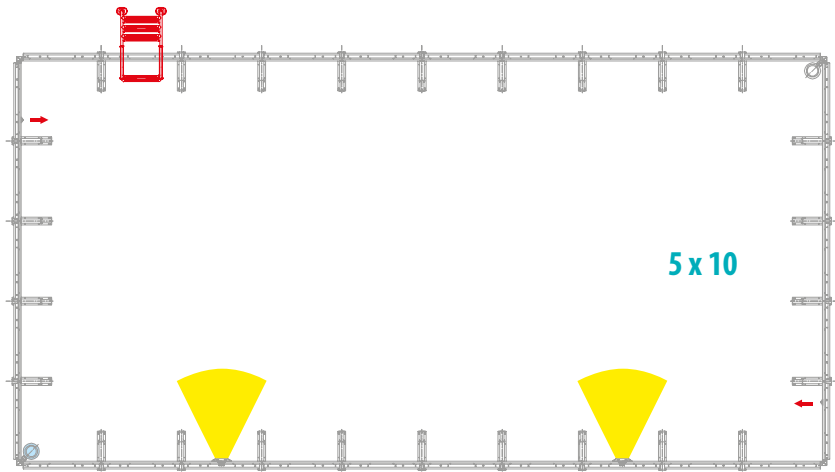

* PARA ESTAS DIMENSÕES, NÃO É POSSÍVEL COLOCAR A ESCADA NO CENTRO DO LADO CURTO
* this sizes don't allow to place the ladder in the center of the short side

CONDIÇÕES DE GARANTIA

PISCINE
LAGHETTO®

Cada Piscine Laghetto é fabricada com materiais seleccionados e de acordo com determinados procedimentos de qualidade.

Todas as piscinas Laghetto estão cobertas por uma garantia de 24 meses.

No que diz respeito às garantias complementares, após registo no prazo de 30 (trinta) dias a contar da data de entrega, através do formulário dedicado no site www.piscinelaghetto.com, o utilizador final, fornecendo a documentação necessária (fatura ou documento de venda e, se necessário, número de série do Produto), pode solicitar as seguintes garantias complementares

A "lona" e a "estrutura metálica" da piscina modelo "Classic" podem ser objeto de uma garantia de 3 (três) anos.

A "lona" e a "estrutura metálica" das piscinas modelo "Pop!", "DolceVita", "Playa", "Divina", "Divina Infinity", "Ninfea" podem ser objeto de uma garantia de 5 (cinco) anos. As substituições ou reparações efectuadas em conformidade com esta garantia não prolongam o período de garantia do produto de origem, mas beneficiam de uma garantia própria.

Em qualquer caso, a garantia só se aplica se as piscinas, produtos e componentes forem utilizados de forma adequada e correcta e se forem instalados por pessoal qualificado, especializado e certificado pela Fluidra.

A garantia não cobre as utilizações do produto não expressamente previstas pelo fabricante.

A garantia é "à saída da fábrica" e cobre, pelo período de 24 meses ou pelo período de garantia mais longo acima acordado, os custos do material e da mão de obra necessários para a reparação e/ou restauro do produto, que serão efectuados nas instalações da Vescovato (CR), em Ex S.s. Padana Inferiore, 11/C.

A critério inquestionável da Fluidra, caso a reparação ou restauro não seja possível ou não seja rentável, o produto será substituído por outro com características idênticas ou semelhantes.

Todos os custos incorridos pela Fluidra relativamente à reparação e/ou restauro dos bens, efectuados fora do período de garantia, serão sempre suportados pelo cliente.

Uma vez expirado o período de garantia, o custo das reparações e eventuais encargos conexos (por exemplo, custos de envio) serão suportados integralmente pelo comprador.

Após o termo do período de garantia, não é garantida a disponibilidade de materiais e peças sobressalentes para substituição de eventuais peças defeituosas.

O fabricante e/ou o vendedor não podem ser responsabilizados por este facto.

A garantia acima concedida terá início a partir da data de entrega do produto ao cliente final e será válida pelo período indicado nesta tabela de preços (24 meses) ou 3 anos ou 5 anos, desde que o cliente final esteja na posse do documento fiscal comprovativo da compra e o pedido de extensão de garantia seja efectuado no prazo de 30 (trinta) dias a contar da data de compra do Produto.

Ficam excluídos da garantia quaisquer danos causados aos produtos por geada ou utilização inadequada de produtos químicos ou utilização de produtos químicos de marcas não pertencentes à Fluidra, ou de outros fabricantes, não comunicados e especificamente aprovados pela Fluidra.

Estão igualmente excluídos das condições de garantia os defeitos e avarias imputáveis a uma utilização incorrecta dos bens.

Os custos de esvaziamento, enchimento e tratamento químico da água nunca são cobertos pela garantia e, portanto, não podem ser atribuídos à Fluidra. Outras condições de exclusão estão expressamente indicadas no certificado de garantia específico que acompanha o produto e nas condições gerais de venda da Fluidra.

Para que esta garantia seja efectiva, o Comprador deverá apresentar prova da data de compra e recepção do Produto. Para além disso, o Comprador deverá seguir escrupulosamente as instruções do Vendedor contidas na documentação que acompanha o Produto, quando aplicável, consoante a gama e o modelo do Produto.

As peças substituídas ou reparadas ao abrigo desta garantia não prolongam o período de garantia do Produto original, mas têm a sua própria garantia.

IMPORTANTE:

1- A lona da piscina é constituída por uma membrana de tecido de poliéster (trevisca) revestido de PVC montado numa só peça. Aquando do primeiro enchimento e durante as primeiras semanas de utilização, a membrana da banheira pode escorrer sob a forma de gotas, nomeadamente nos cantos. Trata-se de uma condição fisiológica do material que não afecta de modo algum a estanquidade mecânica e a vida útil da lona e não constitui um defeito. Por conseguinte, não dá direito a qualquer reclamação de garantia para o próprio material. Recomenda-se deixar secar a transudação sem retirar as gotas; o fenómeno desaparecerá em pouco tempo. A duração do fenómeno pode variar em função do local de instalação, da temperatura exterior e/ou da temperatura da piscina e da utilização de produtos de tratamento adequados.

2- Em determinadas condições ambientais, podem formar-se bolores resistentes no tecido tubular. Estes não afectam a durabilidade nem a resistência do material, não afectam a sua utilização, não constituem um defeito e não dão lugar a qualquer reclamação de garantia.

3- A lona da piscina pode sofrer alterações na sua cor original ao longo do tempo devido ao seu envelhecimento, à exposição prolongada ao sol e/ou às intempéries e à utilização contínua de produtos químicos de tratamento e/ou limpeza. Este fenómeno não afecta a resistência estrutural do produto, não afecta de modo algum a sua utilização e, por conseguinte, não dá direito a qualquer reclamação de garantia.

4- A oxidação das partes metálicas devida à falta de manutenção ou a uma manutenção inadequada ou não efectuada de acordo com as instruções do produto Piscine Laghetto e/ou a diligência exigida pela natureza do produto não deve ser considerada como um defeito, não afecta a resistência estrutural do produto, não afecta de modo algum a sua utilização e não dá, portanto, direito a qualquer pedido de substituição ao abrigo da garantia.

5- Todas as partes de acabamento dos produtos (por exemplo, revestimentos, cantos, tecidos) são maioritariamente feitas à mão. Como tal, certas imperfeições destas partes devem ser consideradas como características intrínsecas e aceites do produto. Não afectam a utilização a que o produto se destina. Não devem ser consideradas como um defeito, não afectam a resistência estrutural do produto, não afectam a sua utilização de forma alguma e, portanto, não dão origem a qualquer reclamação de garantia.

6- A garantia alargada de 3 ou 5 anos para o tecido e a estrutura metálica não se aplica se for instalado um sistema de electrólise de sal no produto DolceVita, Divina, Pop ou Classic. Neste caso, o período de garantia é limitado a 2 anos. No produto Playa, a instalação de um sistema de electrólise de sal e/ou qualquer outro tipo de sistema de filtragem/desinfeção que não seja o original fornecido pela Fluidra no momento da compra do produto, invalida automaticamente a garantia fornecida pelo fabricante.

7- A garantia não se aplica à borda da piscina de qualquer tipo de piscina DolceVita, Divina, Pop!, Classic se esta for utilizada incorrectamente, ou seja, não estiver de acordo com as instruções de montagem, utilização e/ou manutenção fornecidas com a própria piscina.

Todas as outras informações relativas à garantia (objeto, duração, exclusões, inaplicabilidade, caducidade, responsabilidade por danos) estão incluídas nas CONDIÇÕES GERAIS DE VENDA e, mais pormenorizadamente, nos certificados Piscines Laghetto, nas instruções de instalação e de manutenção que acompanham os produtos.

RESERVAMO-NOS O DIREITO DE MODIFICAR, MESMO SEM AVISO PRÉVIO, A TOTALIDADE OU PARTE DO CONTEÚDO DESTA DOCUMENTO.



ATENÇÃO

EXTENSÃO DA GARANTIA | Extended warranty

Para obter a extensão de garantia anunciada neste catálogo, o produto deve ser registado pelo cliente final em www.piscinelaghetto.com no prazo de 30 dias a contar da data de entrega da piscina, comprovada por um recibo/fatura fiscal regular.

In order to obtain the extended warranty advertised in this catalogue, the product must be registered by the end customer on www.piscinelaghetto.com within 30 days from the date of sale/delivery of the pool, proven by regular fiscal receipt/invoice.

Dolce Vita



WARRANTY CONDITIONS

Each Laghetto pool is manufactured from selected materials and according to certain quality procedures.

Each Laghetto pool is covered by a 24-month guarantee.

As regards additional warranties, upon written request within 30 (thirty) days from the date of purchase/delivery and through the dedicated form on the website www.piscinelaghetto.com, the end user, providing the necessary documentation (invoice or purchase document and, where required, serial number of the Product) may request the following additional guarantees:

The "liner" and the "metal structure" of the "Classic" swimming pool model may be covered by a guarantee for the duration of 3 (three) years.

The "liner" and the "metal structure" of the "Pop!", "Dolcevita", "Playa", "Divina", "Divina Infinity", "Ninfea" swimming pools models, shall be covered by a guarantee for the duration of 5 (five) years.

In any case, the guarantee shall apply only in the event of proper and correct use of the pools, products and components and on the condition that they are installed by qualified, specialised and Fluidra-certified service personnel.

The warranty does not cover uses of the product not expressly intended by the manufacturer.

The warranty is 'ex-works' and covers, for the period of 24 months or for the longer warranty period as agreed upon above, the costs of the material and labour necessary for the repair and/or restoration of the product, which will be carried out at the premises in Vescovato (CR), ex.s.s. Padana Inferiore, 11/C, Italy. At Fluidra's unquestionable discretion, should repair or restoration not be possible or not be economic, the product shall be replaced with another product having identical or similar characteristics.

All costs incurred by Fluidra with respect to repair and/or restoration of the product, carried out outside of the warranty period, shall always be charged to the customer.

Once the warranty period has expired, the cost of repairs and any related charges (e.g. shipping costs) shall be borne entirely by the customer.

After the expiry of the guarantee period, the availability of materials and spare parts to replace those that may prove to be defective shall not be ensured. No liability in this respect can be charged to the manufacturer and/or to the retailer.

The warranty as granted above shall run from the date of delivery/sale of the product to the end Customer and shall be valid for the period indicated in this price list (24 months) or 3 years or 5 years, on condition that the end Customer is in possession of the fiscal document proving the purchase and the request for extension of the warranty is made within 30 (thirty) days from the date of purchase of the Product.

Any damage caused to the products by frost or inappropriate use of chemicals or use of chemicals of brands not belonging to Fluidra, or of other manufacturers, not disclosed and specifically approved by Fluidra, are excluded from the warranty. Also excluded from the warranty conditions are defects and malfunctions due to improper and/or incorrect use of the goods.

Charges due to emptying, filling and chemical treatment of water are never covered by warranty and therefore cannot be blamed to Fluidra. Other exclusion conditions are expressly stated in the specific warranty certificate accompanying the product and in Fluidra's general terms and conditions of sale.

For this warranty to be effective, the purchaser must provide proof of the date of purchase and receipt of the Product. Furthermore, the Buyer shall scrupulously follow the Seller's instructions contained in the documentation accompanying the Product, where applicable, depending on the range and model of the Product.

Parts replaced or repaired under warranty shall not extend the warranty period of the original Product, but shall have their own warranty period.

IMPORTANT:

1 - The pool liner consists of a membrane made of polyester fabric (trevira) coated with PVC, assembled in one piece. Temporary phenomena of exudation of the pool liner (dripping), due to the type of material used and the welding process of the pvc liner itself, may be evident in particular at the first filling and in the first weeks of use of the product. This is a physiological condition of the material which in no way affects the mechanical tightness life of the pool liner and does not represent a defect. It therefore does not give any right to warranty claims for the material itself. In the event of dripping, it is recommended to allow the dripping to dry without removing the drops in order to accelerate the closing of the weave of the liner. The duration of the phenomenon may vary depending on the place of installation, the temperature outside and/or in the pool and the use of suitable treatment products.

2 - Under certain environmental conditions, resistant mould may develop on the pool liner. These do not affect either the durability or the strength of the material, do not affect its use in any way, do not represent a defect and do not give rise to any warranty claims.

3 - The pool liner may change in its original colour over time due to ageing, prolonged exposure to sunlight and/or weather conditions and the continuous use of treatment and/or cleaning chemicals. This phenomenon does not affect the structural strength of the product, does not affect its use in any way, and therefore does not give right to any warranty claim.

4 - Oxidation of metal parts due to lack of or inadequate maintenance or maintenance not carried out in accordance with Piscine Laghetto Product instruction manuals and/or the diligence required by the nature of the product are not to be considered a defect, do not affect the structural resistance of the product, do not prejudice its use in any way, and therefore do not give right to any request for replacement under warranty.

5 - All finishing parts of the products (by way of example: panelling, edges, fabrics) are mainly handmade. As a result, certain imperfections in these parts are to be considered as intrinsic and accepted characteristics of the product. They do not affect the use for which the product is intended. They are not to be considered a defect, do not affect the structural strength of the product, do not affect its use in any way, and therefore do not give rise to any warranty claim.

6 - The extended warranty of 3 or 5 years on the pool liner and metal structure does not apply if a salt electrolysis system is installed on the Dolcevita, Divina, Pop or Classic product. In this case the warranty period is limited to 2 years. On the Playa product the installation of a salt electrolysis system and/or any other type of filtration/disinfection system other than the original one supplied by Fluidra at the time of purchase of the product, automatically invalidates the warranty provided by the manufacturer.

7 - The warranty does not apply to the pool edge of any type of Dolcevita, Divina, Pop!, Classic pools if it is used incorrectly, i.e. not in accordance with the assembly, use and/or maintenance instructions supplied with the pool itself.

Any other further details concerning the warranty (object, duration, exclusions, inapplicability, charges, liability for damages) are included in the GENERAL CONDITIONS OF SALE and, in greater detail, in the PiscineLaghetto certificates included in the installation and maintenance manuals accompanying the products.

WE RESERVE THE RIGHT TO MODIFY, EVEN WITHOUT PRIOR NOTICE, ALL AND/OR PART OF THE CONTENTS OF THIS DOCUMENT.



WARNING

EXTENDED WARRANTY

In order to obtain the extended warranty advertised in this catalogue, the product must be registered by the end customer on www.piscinelaghetto.com within 30 days from the date of sale/delivery of the pool, proven by regular fiscal receipt/invoice

Dolce Vita



PISCINE
LAGHETTO[®]

www.piscinelaghetto.com

FICA EM CONTACTO CONNOSCO
STAY CONNECTED



50

1974
2024

Dalce Vita